

4

3

2

1

ITEM NO.	PART NUMBER	DESCRIPTION	QTY.
1	RF-DET001 (Link)		2
2	RF-DET002 (Mount 1)		1
3	RF-DET003 (Mount 1-2)		1
4	RF-DET004 (Mount 2)		1
5	RF-DET005 (Front)		2
6	RF-DET006 (Rear)		2
7	RF-SUB01-DET001 (HingeBracket)		1
8	RF-SUB01-DET002		1
9	RF-SUB03-DET001 (CuffAttach)		1
10	RF-SUB03-DET002 (LinkAttach)		1
11	RF-SUB03-DET003 (Cuff L)		1
12	RF-MOTOR (External)	CubeMars AK45-36	2
13	RF-MOTOR (Internal)		2
14	94645A102	High-Strength Steel Nylon-Insert Locknut	2
15	92981A103	Alloy Steel Shoulder Screws	2
16	94710A101	18-8 Stainless Steel Nylon-Insert Flange Locknut	4
17	91239A129		4
18	57155K588	Flanged Ball Bearing	4
19	92095A182		12
20	97163A154		16
21	91239A224	Button Head Hex Drive Screw	20
22	91239A113	Button Head Hex Drive Screw	22

B

B

A

A

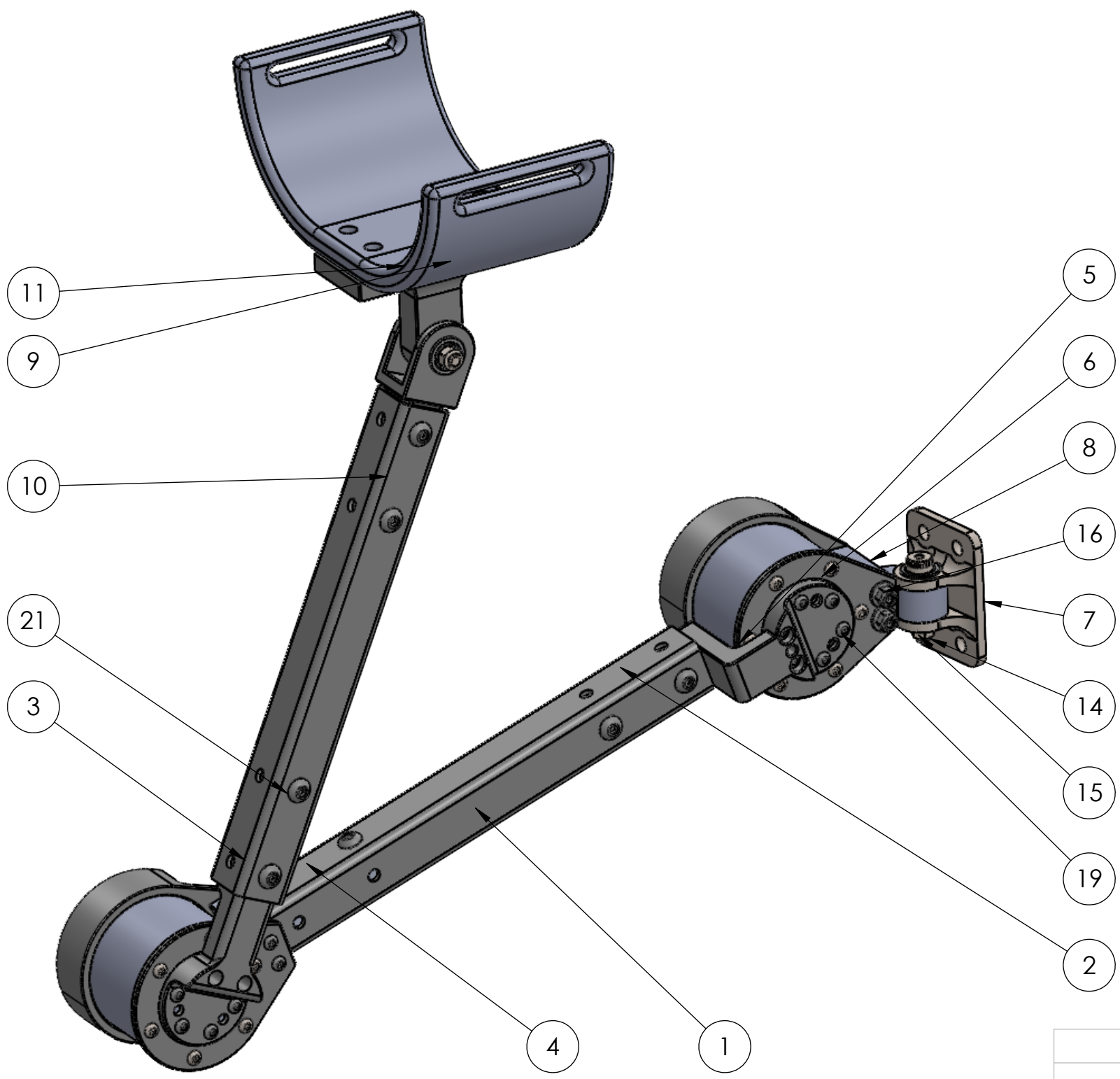

**PROPRIETARY AND CONFIDENTIAL**  
 THE INFORMATION CONTAINED IN THIS DRAWING IS THE SOLE PROPERTY OF <INSERT COMPANY NAME HERE>. ANY REPRODUCTION IN PART OR AS A WHOLE WITHOUT THE WRITTEN PERMISSION OF <INSERT COMPANY NAME HERE> IS PROHIBITED.

		UNLESS OTHERWISE SPECIFIED:	NAME	DATE	TITLE: <b>TOP LEVEL</b>
		DIMENSIONS ARE IN INCHES	DRAWN		
		TOLERANCES: FRACTIONAL ±	CHECKED		
		ANGULAR: MACH ± BEND ±	ENG APPR.		
		TWO PLACE DECIMAL ±	MFG APPR.		SIZE DWG. NO. REV
		THREE PLACE DECIMAL ±	Q.A.		<b>B</b> <b>FINAL</b>
		INTERPRET GEOMETRIC TOLERANCING PER:	COMMENTS:		SCALE: 1:2 WEIGHT: SHEET 1 OF 16
NEXT ASSY	USED ON	MATERIAL			
APPLICATION		FINISH	DO NOT SCALE DRAWING		

4

3

2

1

4

3

2

1

ITEM NO.	PART NUMBER	DESCRIPTION	QTY.
1	RF-SUB01-DET001 (HingeBracket)		1
2	RF-SUB01-DET002		1
3	57155K588	Flanged Ball Bearing	2
4	92981A103	Alloy Steel Shoulder Screws	1
5	94645A102	High-Strength Steel Nylon-Insert Locknut	1

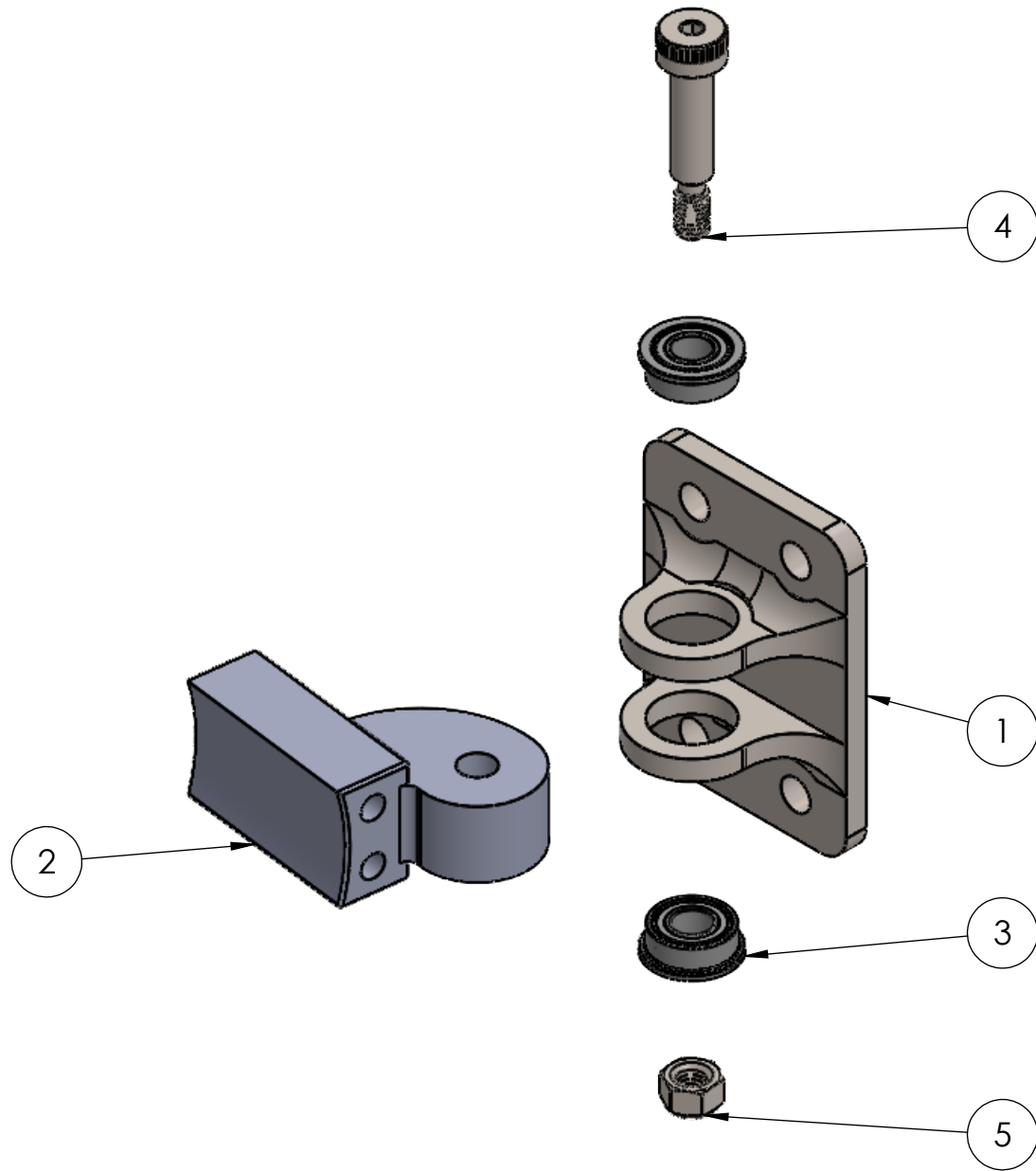

EXPLODED ISOMETRIC VIEW  
SCALE 1:1

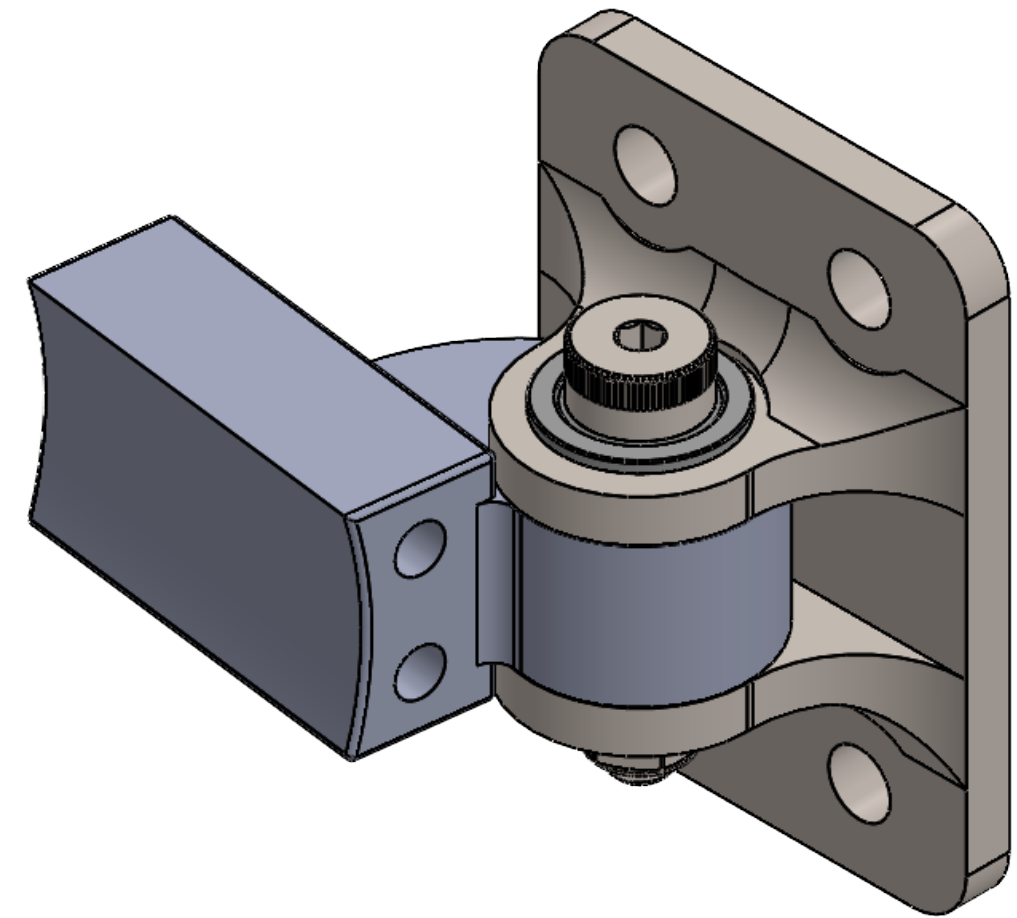

ISOMETRIC VIEW  
SCALE 2:1

**PROPRIETARY AND CONFIDENTIAL**  
THE INFORMATION CONTAINED IN THIS DRAWING IS THE SOLE PROPERTY OF <INSERT COMPANY NAME HERE>. ANY REPRODUCTION IN PART OR AS A WHOLE WITHOUT THE WRITTEN PERMISSION OF <INSERT COMPANY NAME HERE> IS PROHIBITED.

		UNLESS OTHERWISE SPECIFIED:	NAME	DATE	TITLE: <b>SUB01 HINGE SUBASSEMBLY</b>
		DIMENSIONS ARE IN INCHES	DRAWN		
		TOLERANCES: FRACTIONAL ± ANGULAR: MACH ± BEND ± TWO PLACE DECIMAL ± THREE PLACE DECIMAL ±	CHECKED		
		INTERPRET GEOMETRIC TOLERANCING PER:	ENG APPR.		
NEXT ASSY	USED ON	MATERIAL	MFG APPR.		SIZE DWG. NO. REV
APPLICATION		FINISH	Q.A.		<b>B</b> <b>FINAL</b>
		DO NOT SCALE DRAWING	COMMENTS:		SCALE: 1:2 WEIGHT: SHEET 2 OF 16

3

2

1

4

3

2

1

ITEM NO.	PART NUMBER	DESCRIPTION	QTY.
1	RF-MOTOR (External)	CubeMars AK45-36	1
2	RF-MOTOR (Internal)		1
3	RF-DET002 (Mount 1)		1
4	RF-DET005 (Front)		1
5	RF-DET006 (Rear)		1
8	94710A101	18-8 Stainless Steel Nylon-Insert Flange Locknut	2
9	92095A182		6
10	91239A113	Button Head Hex Drive Screw	11

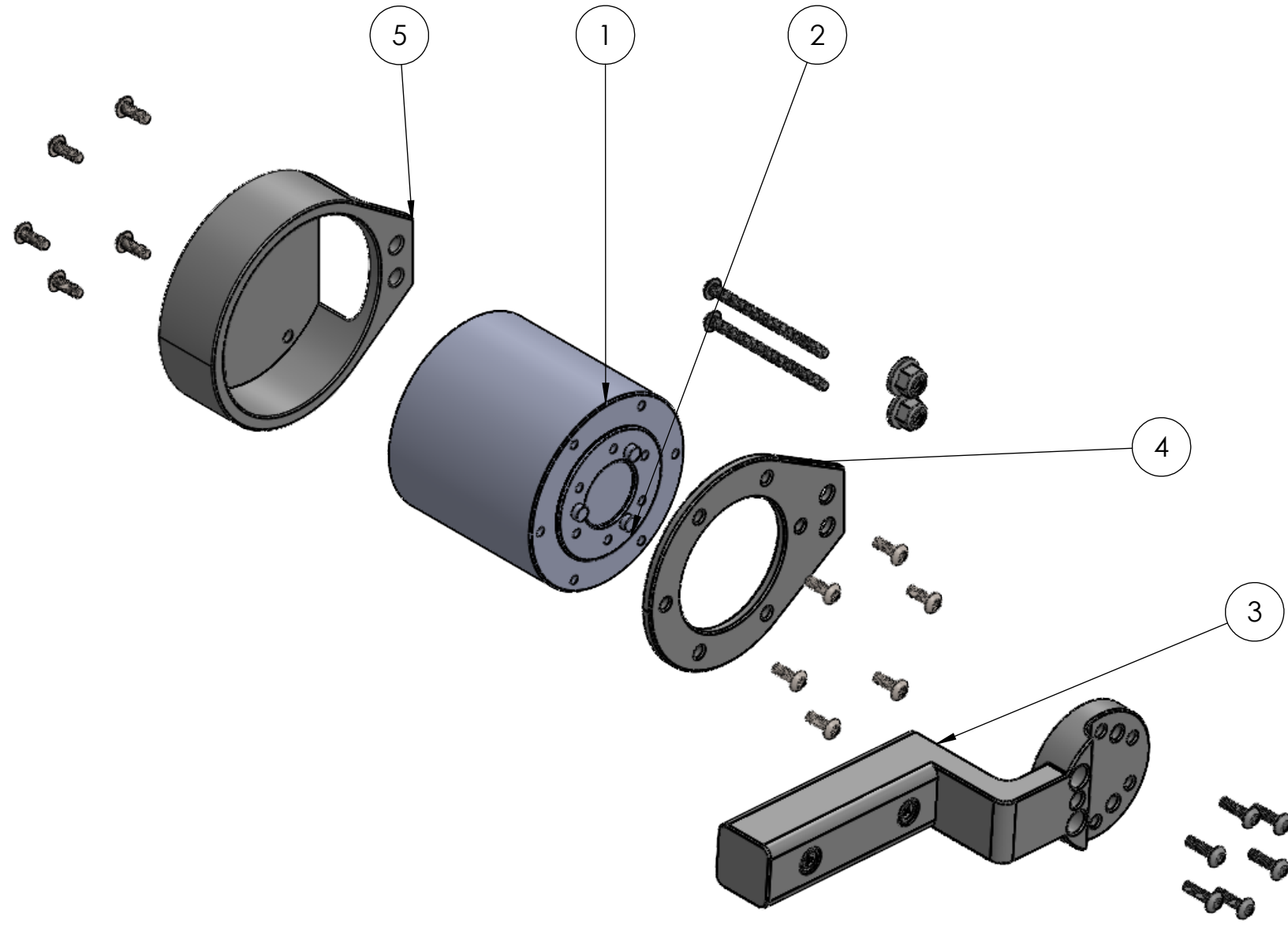

EXPLODED ISOMETRIC VIEW  
SCALE 2:3

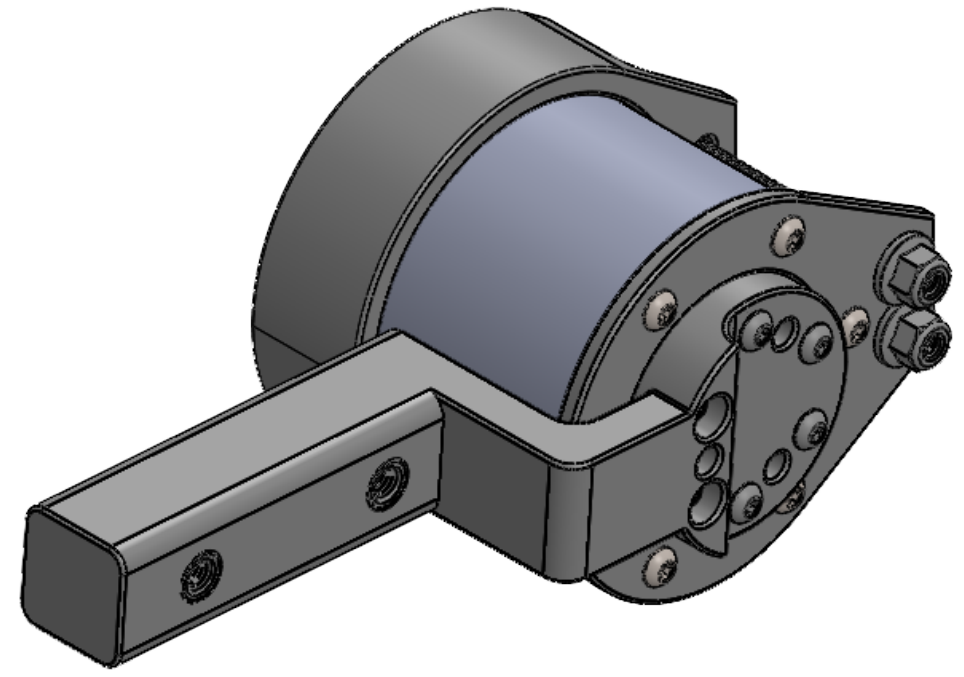

ISOMETRIC VIEW  
SCALE 1:1

**PROPRIETARY AND CONFIDENTIAL**  
THE INFORMATION CONTAINED IN THIS DRAWING IS THE SOLE PROPERTY OF <INSERT COMPANY NAME HERE>. ANY REPRODUCTION IN PART OR AS A WHOLE WITHOUT THE WRITTEN PERMISSION OF <INSERT COMPANY NAME HERE> IS PROHIBITED.

		UNLESS OTHERWISE SPECIFIED:	NAME	DATE		
		DIMENSIONS ARE IN INCHES	DRAWN		TITLE: <b>SUB02-A</b>	
		TOLERANCES:	CHECKED			
		FRACTIONAL: ±	ENG APPR.			
		ANGULAR: MACH ± BEND ±	MFG APPR.			
		TWO PLACE DECIMAL ±	Q.A.		SIZE	DWG. NO.
		THREE PLACE DECIMAL ±	COMMENTS:		<b>B</b>	<b>FINAL</b>
		INTERPRET GEOMETRIC TOLERANCING PER:			SCALE: 1:2	WEIGHT:
		MATERIAL				SHEET 3 OF 16
NEXT ASSY	USED ON	FINISH				
APPLICATION		DO NOT SCALE DRAWING				

3

2

1

4

3

2

1

ITEM NO.	PART NUMBER	DESCRIPTION	QTY.
1	RF-MOTOR (External)	CubeMars AK45-36	1
2	RF-MOTOR (Internal)		1
3	RF-DET003 (Mount 1-2)		1
4	RF-DET005 (Front)		1
5	RF-DET006 (Rear)		1
6	RF-DET004 (Mount 2)		1
7	92095A182		6
8	91239A113	Button Head Hex Drive Screw	11
9	97163A154		8
10	91239A129		2
11	94710A101	18-8 Stainless Steel Nylon-Insert Flange Locknut	2

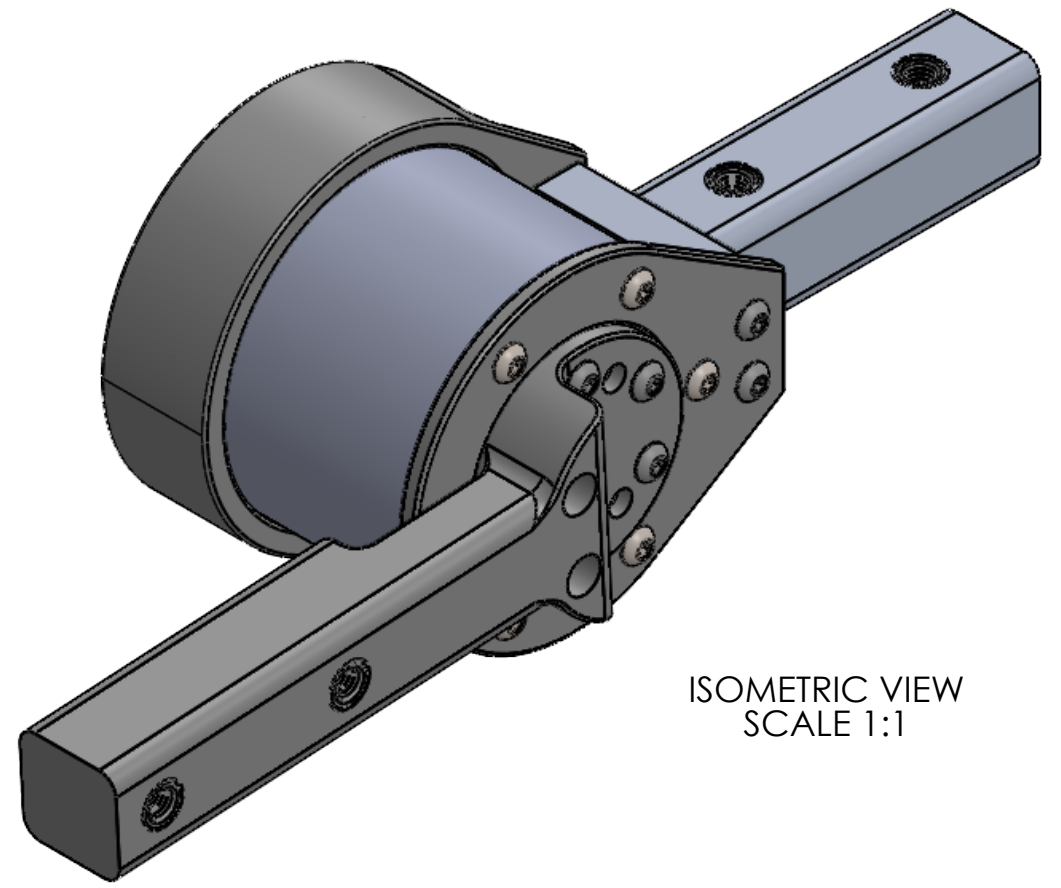
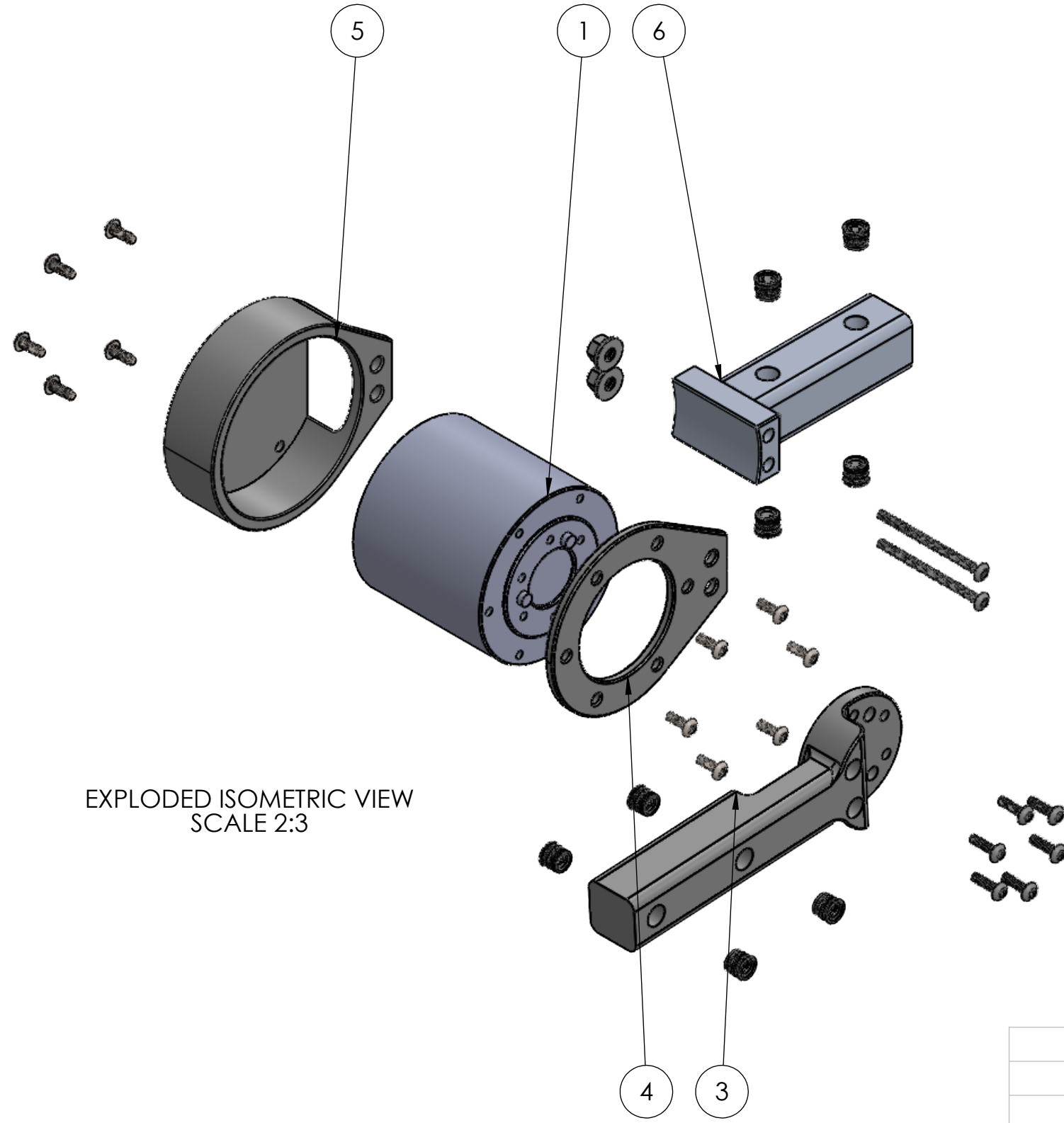

**PROPRIETARY AND CONFIDENTIAL**  
 THE INFORMATION CONTAINED IN THIS DRAWING IS THE SOLE PROPERTY OF <INSERT COMPANY NAME HERE>. ANY REPRODUCTION IN PART OR AS A WHOLE WITHOUT THE WRITTEN PERMISSION OF <INSERT COMPANY NAME HERE> IS PROHIBITED.

		UNLESS OTHERWISE SPECIFIED:	NAME	DATE		
		DIMENSIONS ARE IN INCHES	DRAWN		TITLE: <b>SUB02-B</b>	
		TOLERANCES:	CHECKED			
		FRACTIONAL: ±	ENG APPR.			
		ANGULAR: MACH ± BEND ±	MFG APPR.			
		TWO PLACE DECIMAL ±	Q.A.		SIZE	DWG. NO.
		THREE PLACE DECIMAL ±	COMMENTS:		<b>B</b>	<b>FINAL</b>
		INTERPRET GEOMETRIC TOLERANCING PER:			SCALE: 1:2	WEIGHT:
		MATERIAL				
NEXT ASSY	USED ON	FINISH				REV
APPLICATION		DO NOT SCALE DRAWING				SHEET 4 OF 16

4

3

2

1

4

3

2

1

ITEM NO.	PART NUMBER	DESCRIPTION	QTY.
1	RF-SUB03-DET001 (CuffAttach)		1
2	RF-SUB03-DET002 (LinkAttach)		1
3	RF-SUB03-DET003 (Cuff L)		1
4	57155K588	Flanged Ball Bearing	2
5	92981A103	Alloy Steel Shoulder Screws	1
6	94645A102	High-Strength Steel Nylon-Insert Locknut	1
7	91239A224	Button Head Hex Drive Screw	4
8	97163A154		4

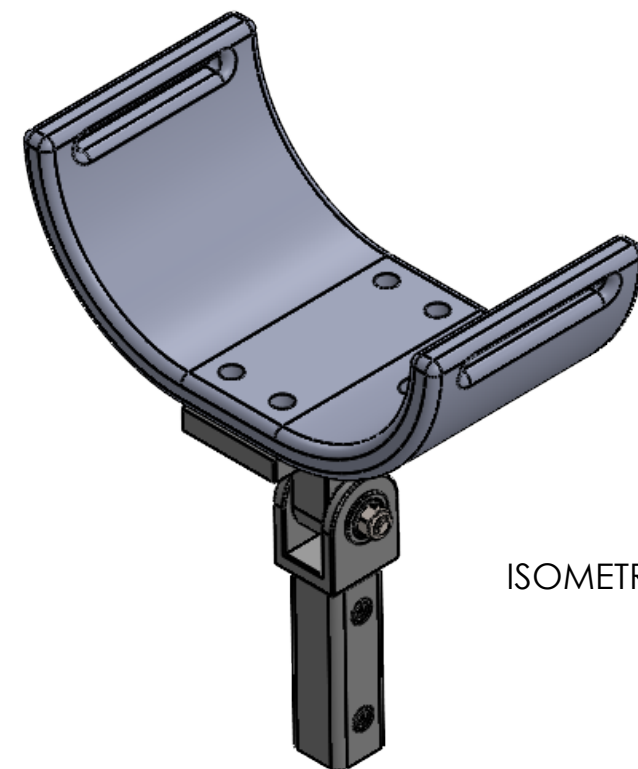
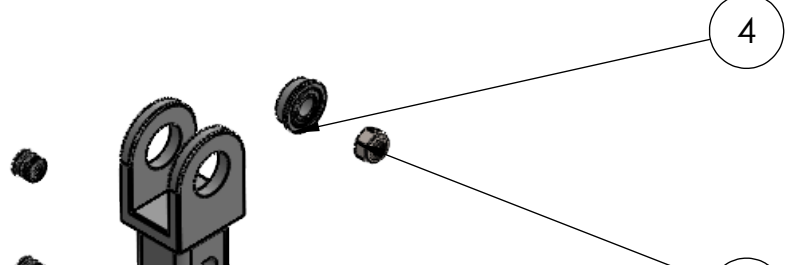
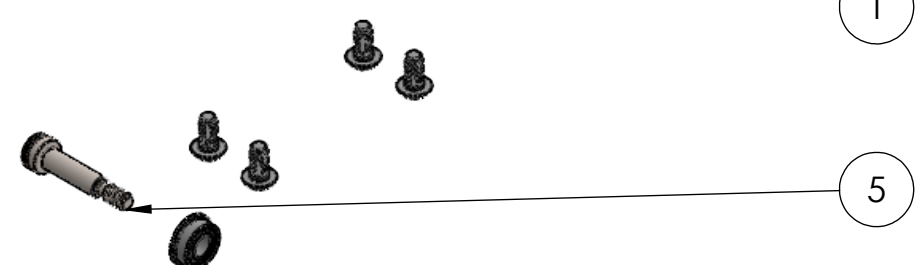
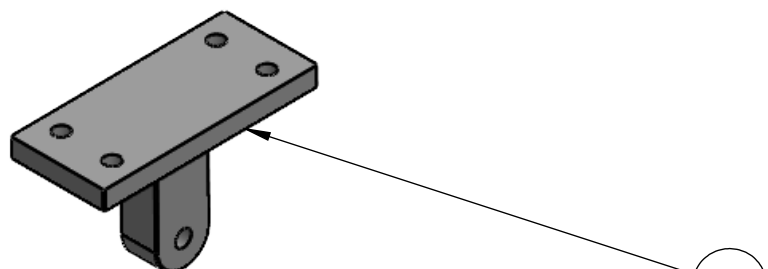
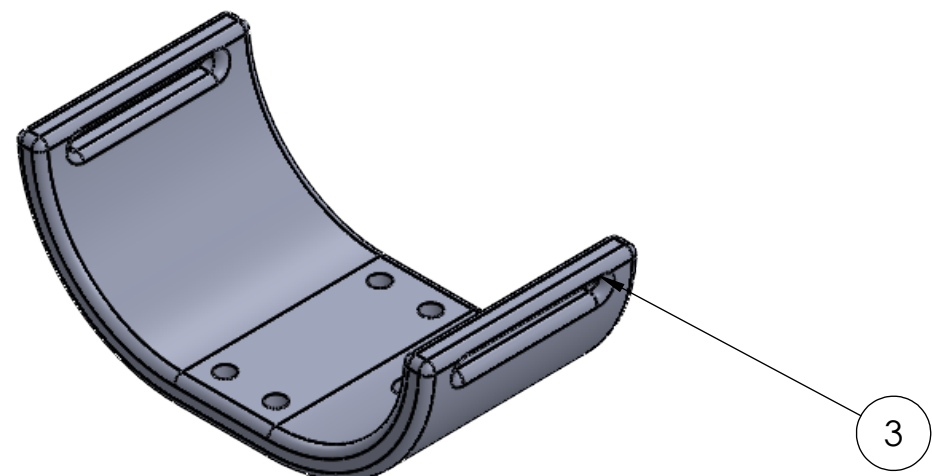

ISOMETRIC VIEW

EXPLODED ISOMETRIC VIEW

**PROPRIETARY AND CONFIDENTIAL**  
 THE INFORMATION CONTAINED IN THIS DRAWING IS THE SOLE PROPERTY OF <INSERT COMPANY NAME HERE>. ANY REPRODUCTION IN PART OR AS A WHOLE WITHOUT THE WRITTEN PERMISSION OF <INSERT COMPANY NAME HERE> IS PROHIBITED.

UNLESS OTHERWISE SPECIFIED:		NAME	DATE
DIMENSIONS ARE IN INCHES		DRAWN	
TOLERANCES:		CHECKED	
FRACTIONAL ±		ENG APPR.	
ANGULAR: MACH ± BEND ±		MFG APPR.	
TWO PLACE DECIMAL ±		Q.A.	
THREE PLACE DECIMAL ±		COMMENTS:	
INTERPRET GEOMETRIC TOLERANCING PER:	MATERIAL		
FINISH			
NEXT ASSY	USED ON		
APPLICATION	DO NOT SCALE DRAWING		

TITLE: <b>SUB03 END EFFECTOR SUBASSEMBLY</b>		
SIZE <b>B</b>	DWG. NO. <b>FINAL</b>	REV
SCALE: 1:2	WEIGHT:	SHEET 5 OF 16

4

3

2

1

4

3

2

1

UNITS IN mm UNLESS OTHERWISE SPECIFIED  
 ALL UNSPECIFIED RADII 0.5  
 THIS DRAWING ADHERES TO Y.14.5 DRAFTING STANDARDS  
 MATERIAL: MACHINED CARBON FIBER

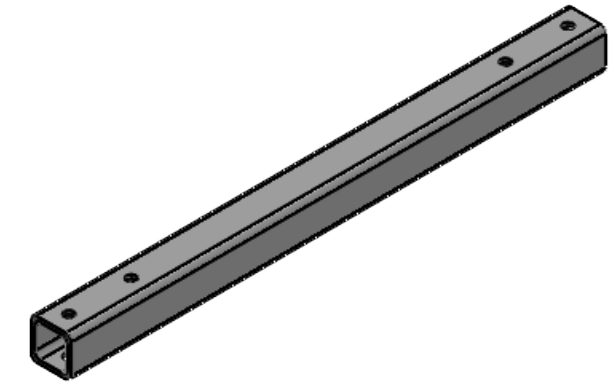
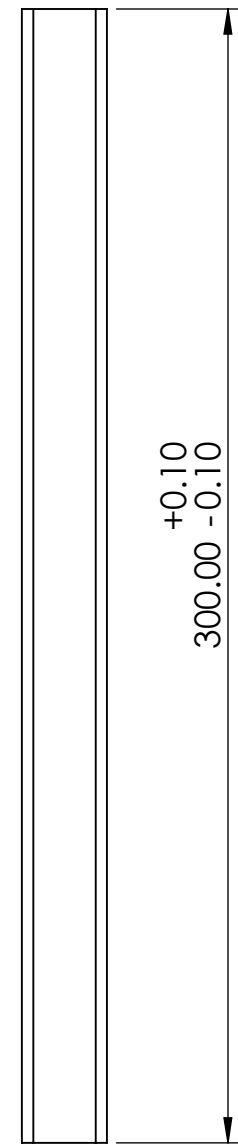
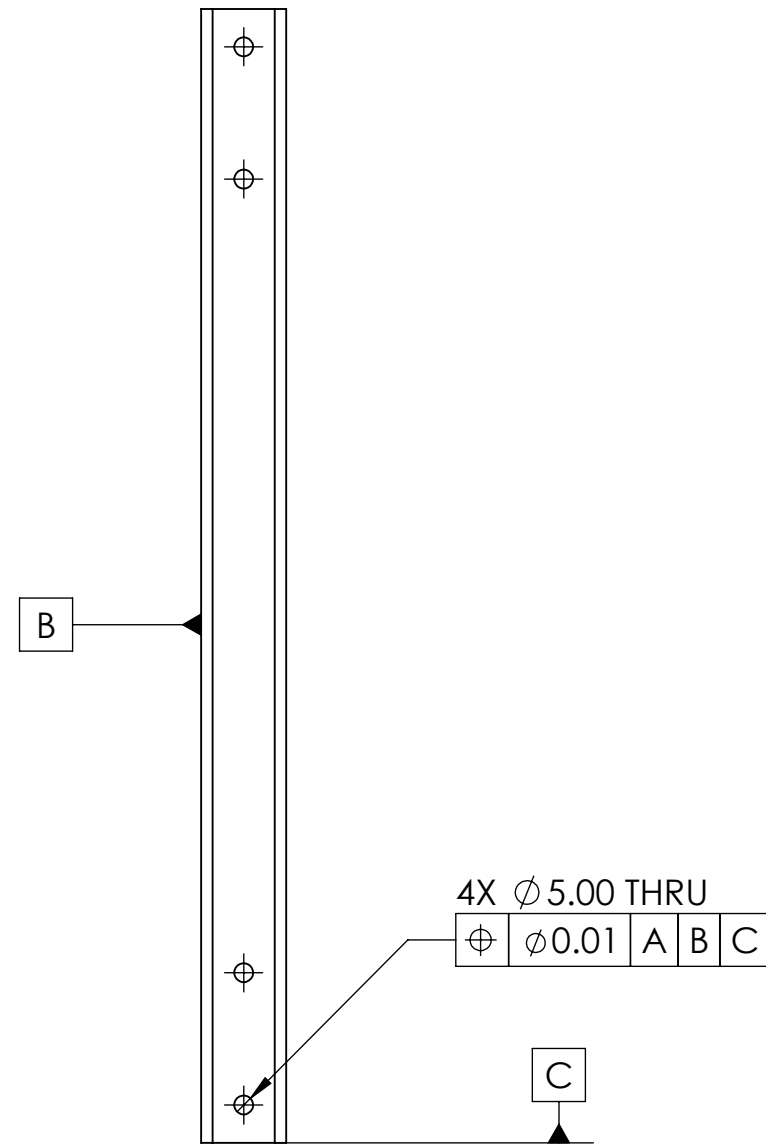

ISOMETRIC VIEW  
 SCALE: 1:3

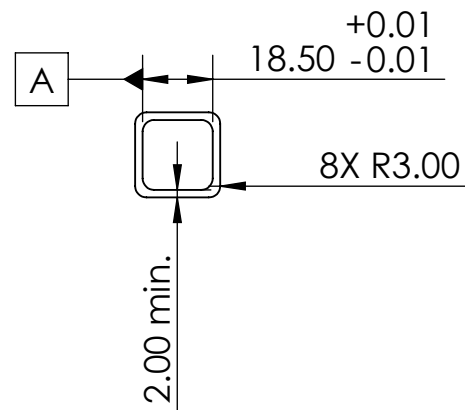

**PROPRIETARY AND CONFIDENTIAL**  
 THE INFORMATION CONTAINED IN THIS DRAWING IS THE SOLE PROPERTY OF <INSERT COMPANY NAME HERE>. ANY REPRODUCTION IN PART OR AS A WHOLE WITHOUT THE WRITTEN PERMISSION OF <INSERT COMPANY NAME HERE> IS PROHIBITED.

		UNLESS OTHERWISE SPECIFIED:	NAME	DATE	TITLE: <b>DET001 ARM LINK</b>
		DIMENSIONS ARE IN INCHES	DRAWN	C. LAMCA	
		TOLERANCES: FRACTIONAL ± ANGULAR: MACH ± BEND ± TWO PLACE DECIMAL ± THREE PLACE DECIMAL ±	CHECKED		
		INTERPRET GEOMETRIC TOLERANCING PER:	ENG APPR.		
		MATERIAL Carbon Fiber	MFG APPR.		SIZE
NEXT ASSY	USED ON	FINISH	Q.A.		DWG. NO. <b>B FINAL</b>
APPLICATION		DO NOT SCALE DRAWING	COMMENTS:		REV
					SCALE: 1:8
					WEIGHT:
					SHEET 6 OF 16

3

2

1

UNITS IN mm UNLESS OTHERWISE SPECIFIED  
 ALL UNSPECIFIED RADII 0.5  
 THIS DRAWING ADHERES TO Y.14.5 DRAFTING STANDARDS  
 MATERIAL: 3D PRINTED ONYX BY MARKFORGED

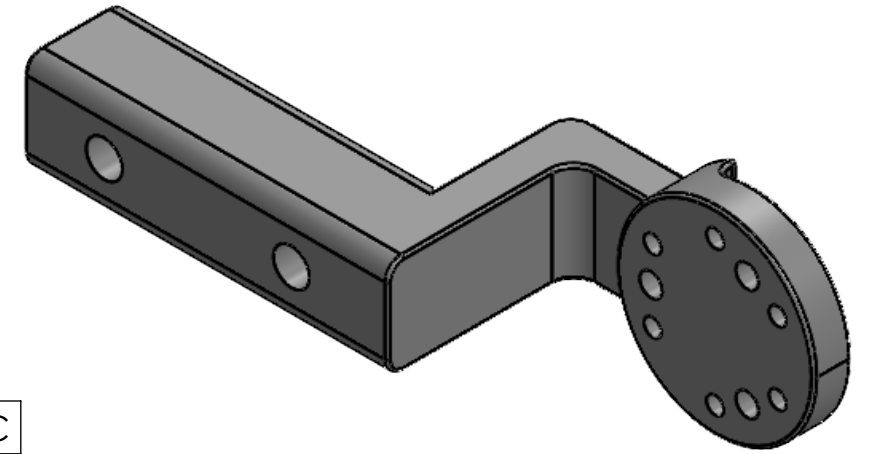
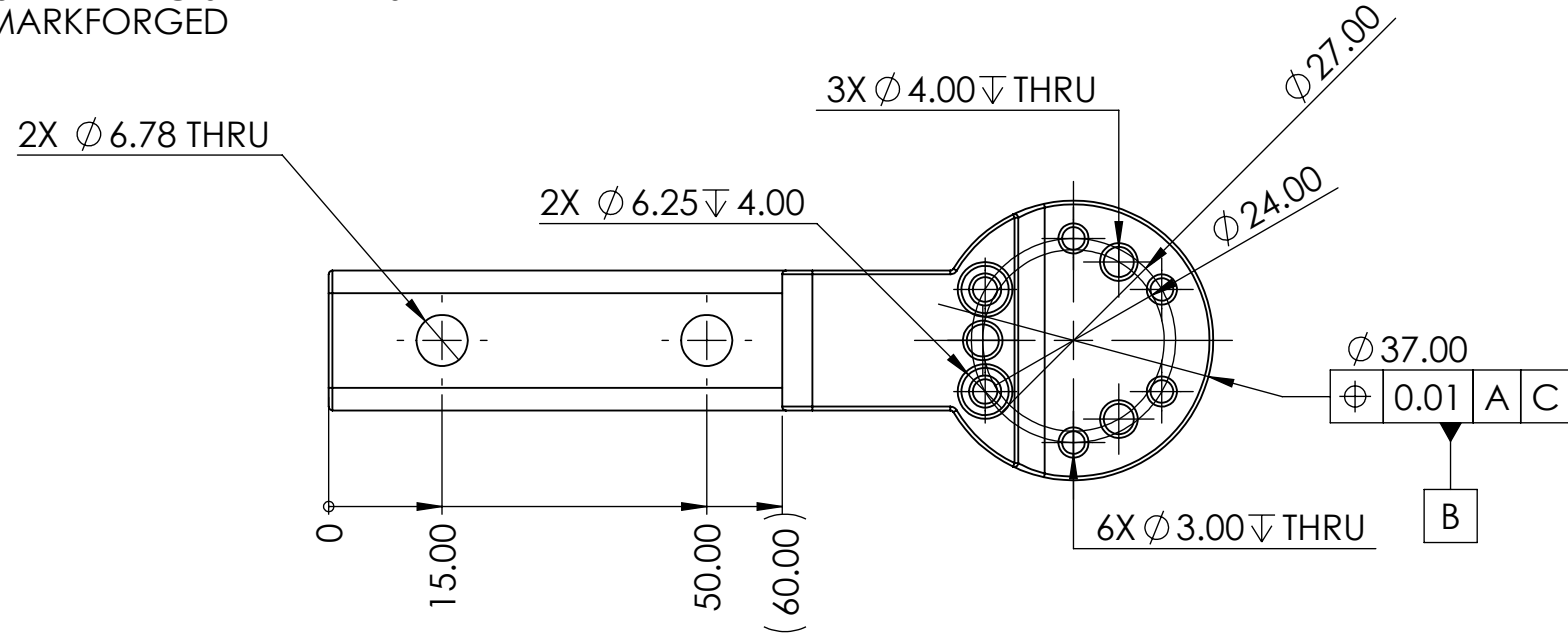

ISOMETRIC VIEW  
 SCALE: 1:1

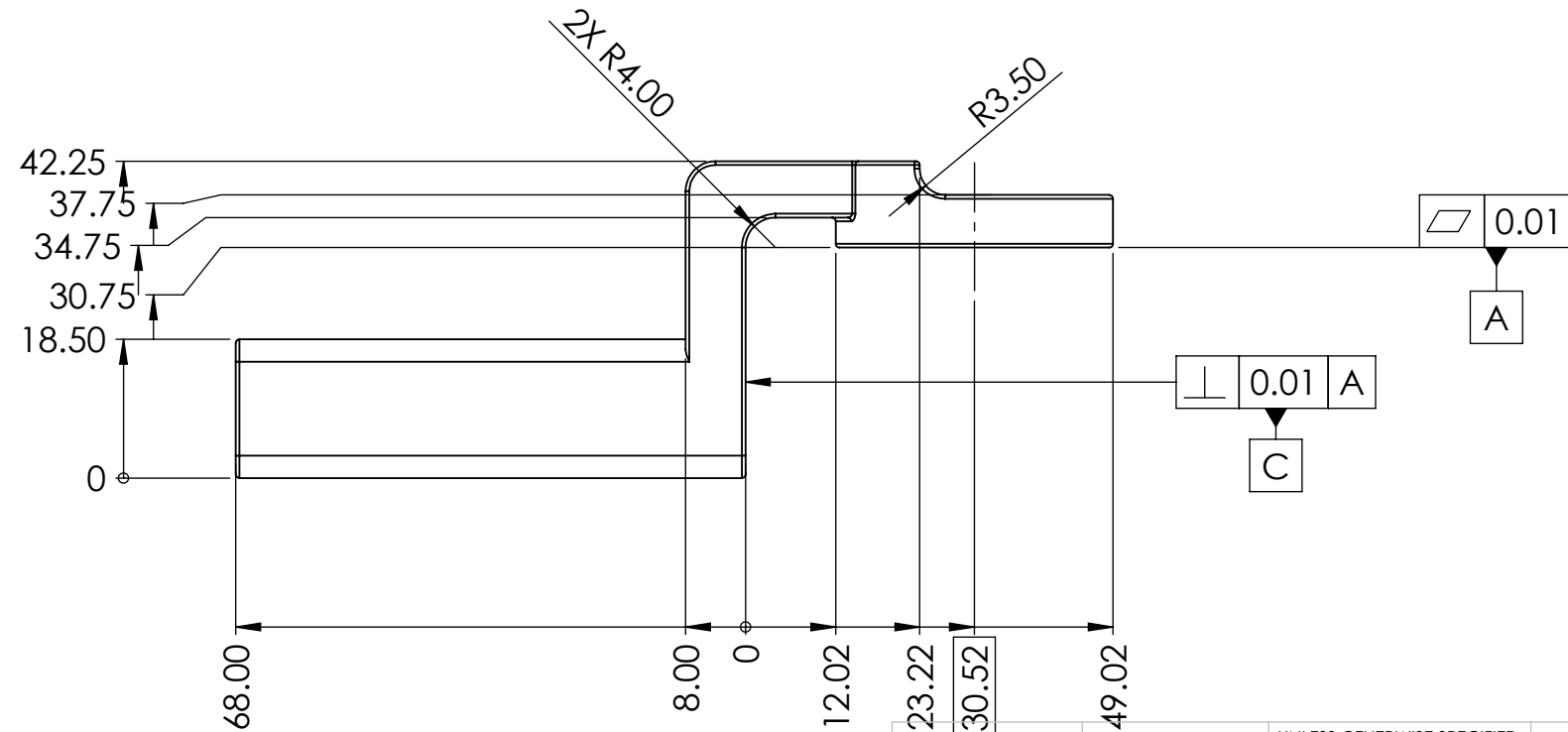
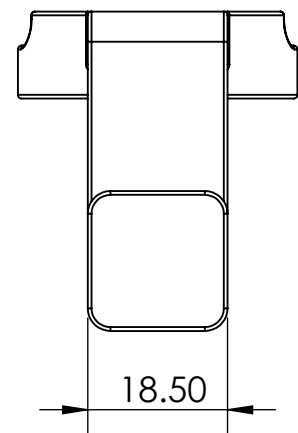

**PROPRIETARY AND CONFIDENTIAL**  
 THE INFORMATION CONTAINED IN THIS DRAWING IS THE SOLE PROPERTY OF <INSERT COMPANY NAME HERE>. ANY REPRODUCTION IN PART OR AS A WHOLE WITHOUT THE WRITTEN PERMISSION OF <INSERT COMPANY NAME HERE> IS PROHIBITED.

UNLESS OTHERWISE SPECIFIED:		NAME	DATE
DIMENSIONS ARE IN INCHES		DRAWN	C. LAMCA
TOLERANCES:		CHECKED	
FRACTIONAL ±		ENG APPR.	
ANGULAR: MACH ± BEND ±		MFG APPR.	
TWO PLACE DECIMAL ±		Q.A.	
THREE PLACE DECIMAL ±		COMMENTS:	
INTERPRET GEOMETRIC TOLERANCING PER:			
MATERIAL			
3D Printed ONYX			
FINISH			
NEXT ASSY	USED ON		
APPLICATION		DO NOT SCALE DRAWING	

TITLE:		
<b>DET002 LINK MOUNT 1</b>		
SIZE	DWG. NO.	REV
<b>B</b>	<b>FINAL</b>	
SCALE: 1:8	WEIGHT:	SHEET 7 OF 16

UNITS IN mm UNLESS OTHERWISE SPECIFIED  
 ALL UNSPECIFIED RADII 0.5  
 THIS DRAWING ADHERES TO Y.14.5 DRAFTING STANDARDS  
 MATERIAL: 3D PRINTED ONYX BY MARKFORGED

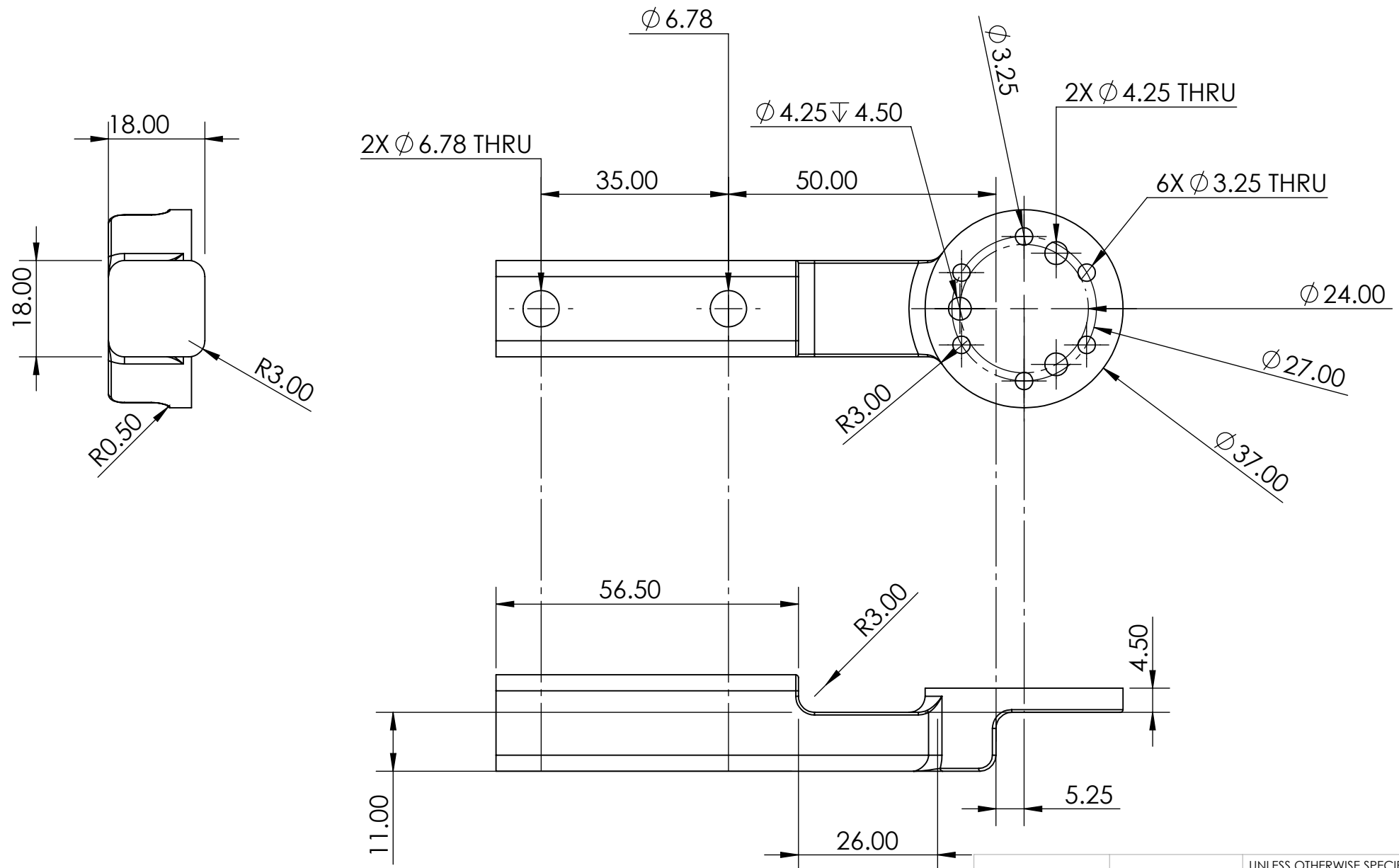
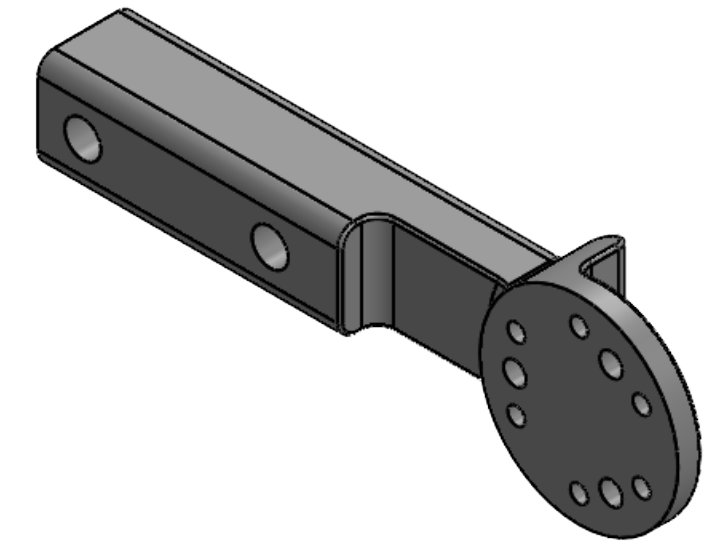

**PROPRIETARY AND CONFIDENTIAL**  
 THE INFORMATION CONTAINED IN THIS DRAWING IS THE SOLE PROPERTY OF <INSERT COMPANY NAME HERE>. ANY REPRODUCTION IN PART OR AS A WHOLE WITHOUT THE WRITTEN PERMISSION OF <INSERT COMPANY NAME HERE> IS PROHIBITED.

UNLESS OTHERWISE SPECIFIED:		NAME	DATE
DIMENSIONS ARE IN INCHES		DRAWN	C. LAMCA
TOLERANCES:		CHECKED	
FRACTIONAL ±		ENG APPR.	
ANGULAR: MACH ± BEND ±		MFG APPR.	
TWO PLACE DECIMAL ±		Q.A.	
THREE PLACE DECIMAL ±		COMMENTS:	
INTERPRET GEOMETRIC TOLERANCING PER:			
MATERIAL			
FINISH			
NEXT ASSY	USED ON		
APPLICATION			
DO NOT SCALE DRAWING			

TITLE:		
<b>DET003 LINK MOUNT 1-2</b>		
SIZE	DWG. NO.	REV
<b>B</b>	<b>FINAL</b>	
SCALE: 1:2	WEIGHT:	SHEET 8 OF 16

4

3

2

1

UNITS IN mm UNLESS OTHERWISE SPECIFIED  
 ALL UNSPECIFIED RADII 0.5  
 THIS DRAWING ADHERES TO Y.14.5 DRAFTING STANDARDS  
 MATERIAL: 3D PRINTED ONYX BY MARKFORGED

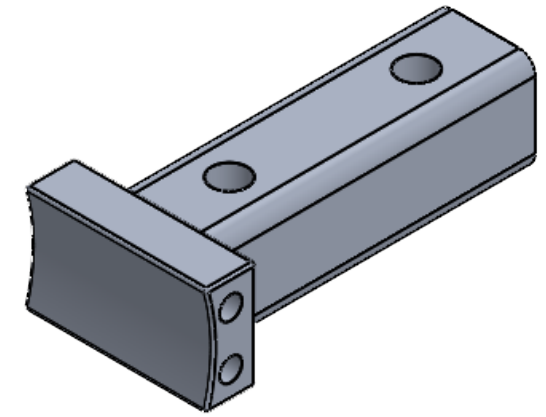

ISOMETRIC VIEW  
SCALE: 1:1

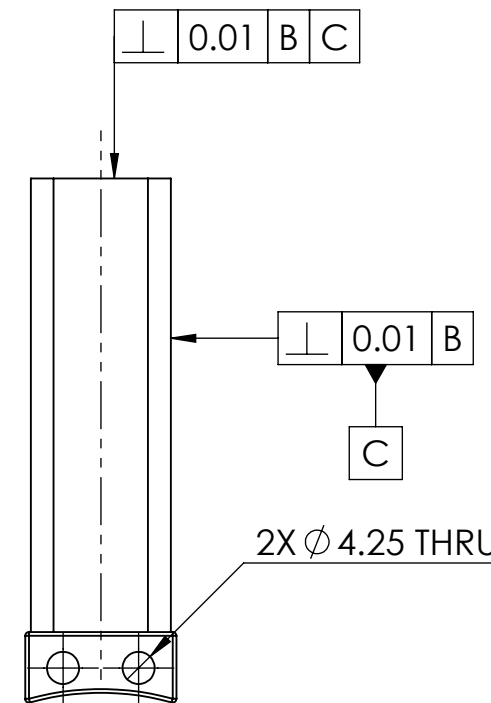
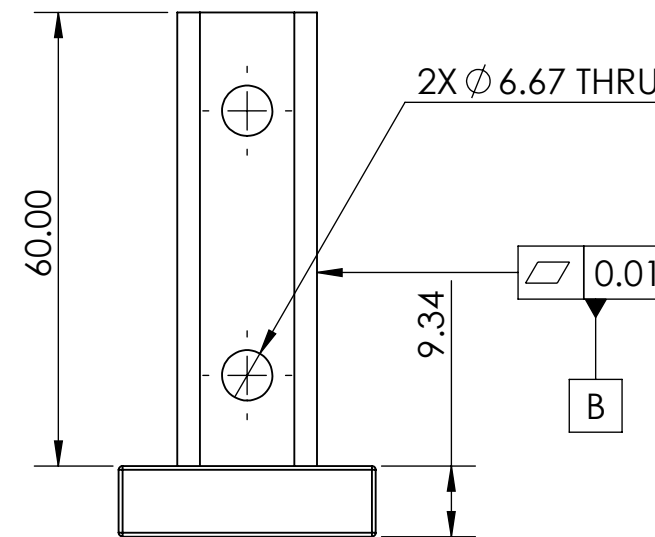
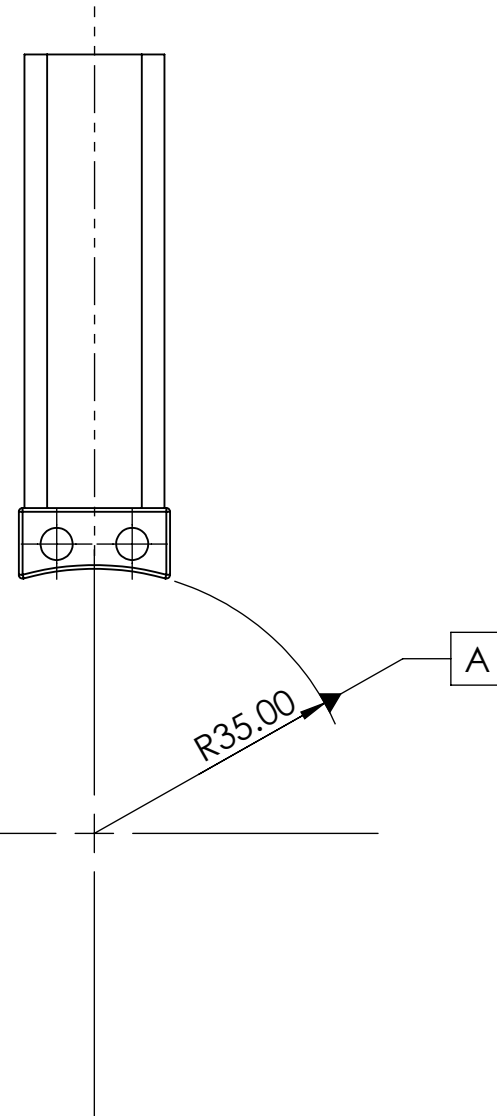
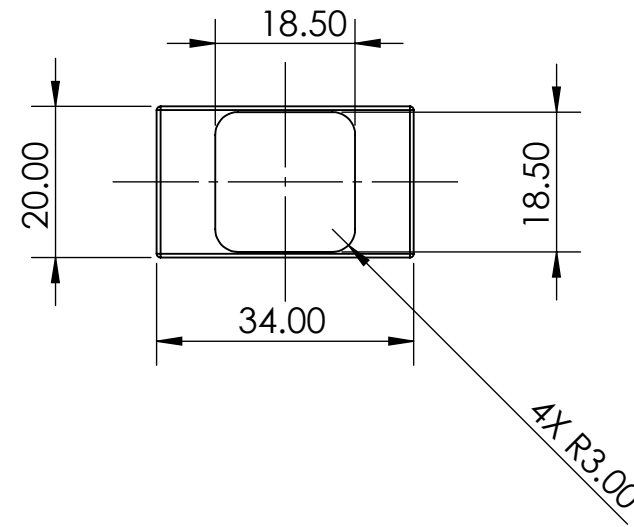

**PROPRIETARY AND CONFIDENTIAL**  
 THE INFORMATION CONTAINED IN THIS DRAWING IS THE SOLE PROPERTY OF <INSERT COMPANY NAME HERE>. ANY REPRODUCTION IN PART OR AS A WHOLE WITHOUT THE WRITTEN PERMISSION OF <INSERT COMPANY NAME HERE> IS PROHIBITED.

		UNLESS OTHERWISE SPECIFIED:		NAME	DATE
		DIMENSIONS ARE IN INCHES		DRAWN	C. LAMCA
		TOLERANCES:		CHECKED	
		FRACTIONAL ±		ENG APPR.	
		ANGULAR: MACH ± BEND ±		MFG APPR.	
		TWO PLACE DECIMAL ±		Q.A.	
		THREE PLACE DECIMAL ±		COMMENTS:	
		INTERPRET GEOMETRIC TOLERANCING PER:		TITLE: <h1>DET004 LINK MOUNT 2</h1>	
		MATERIAL			
		3D Printed ONYX			
NEXT ASSY	USED ON	FINISH		SIZE	DWG. NO.
APPLICATION		DO NOT SCALE DRAWING		<b>B</b>	<b>FINAL</b>
				SCALE: 1:8	WEIGHT:
				REV	
				SHEET 9 OF 16	

3

2

1

UNITS IN mm UNLESS OTHERWISE SPECIFIED  
 ALL UNSPECIFIED RADII 0.5  
 THIS DRAWING ADHERES TO Y.14.5 DRAFTING STANDARDS  
 MATERIAL: 3D PRINTED ONYX BY MARKFORGED

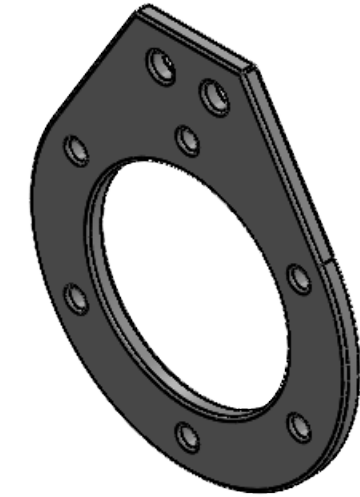
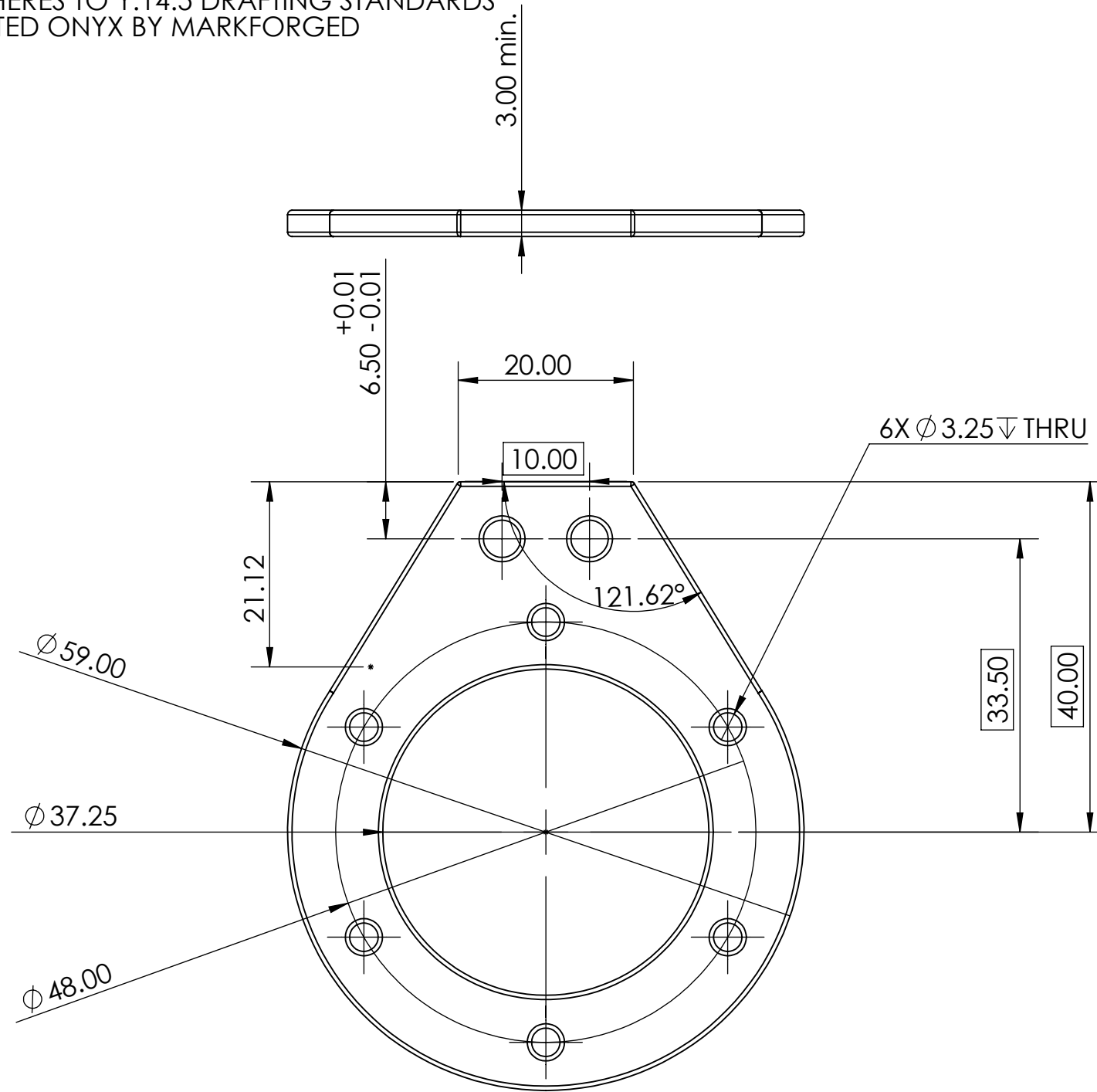

ISOMETRIC VIEW  
 SCALE: 1:1

**PROPRIETARY AND CONFIDENTIAL**  
 THE INFORMATION CONTAINED IN THIS DRAWING IS THE SOLE PROPERTY OF <INSERT COMPANY NAME HERE>. ANY REPRODUCTION IN PART OR AS A WHOLE WITHOUT THE WRITTEN PERMISSION OF <INSERT COMPANY NAME HERE> IS PROHIBITED.

		UNLESS OTHERWISE SPECIFIED:	NAME	DATE		
		DIMENSIONS ARE IN INCHES	DRAWN	C. LAMCA		
		TOLERANCES:	CHECKED		TITLE:	
		FRACTIONAL ±	ENG APPR.		DET005	
		ANGULAR: MACH ± BEND ±	MFG APPR.		FRONT MOTOR MOUNT	
		TWO PLACE DECIMAL ±	Q.A.		SIZE	DWG. NO.
		THREE PLACE DECIMAL ±	COMMENTS:		<b>B</b>	<b>FINAL</b>
		INTERPRET GEOMETRIC TOLERANCING PER:			SCALE: 1:8	WEIGHT:
		MATERIAL				SHEET 10 OF 16
		6061-T6 Aluminum				
NEXT ASSY	USED ON	FINISH				
APPLICATION		DO NOT SCALE DRAWING				

4

3

2

1

UNITS IN mm UNLESS OTHERWISE SPECIFIED  
 ALL UNSPECIFIED RADII 0.5  
 THIS DRAWING ADHERES TO Y.14.5 DRAFTING STANDARDS  
 MATERIAL: 3D PRINTED ONYX BY MARKFORGED

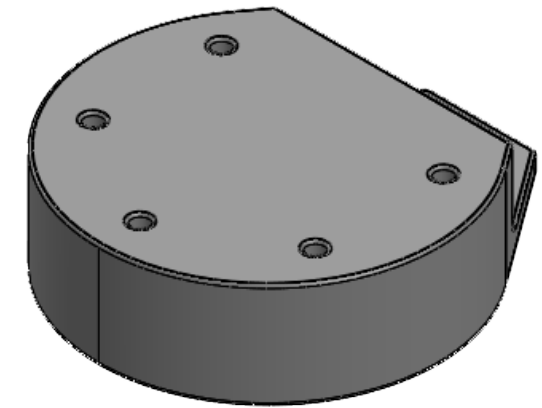

ISOMETRIC VIEW  
SCALE: 1:1

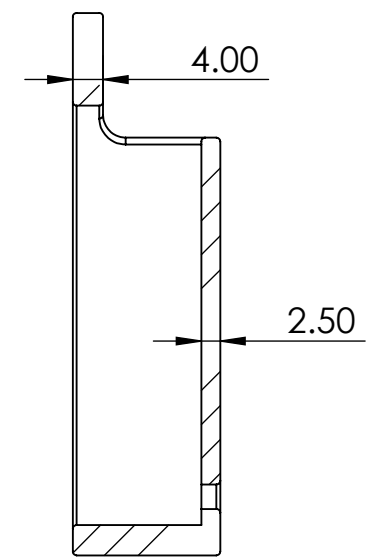
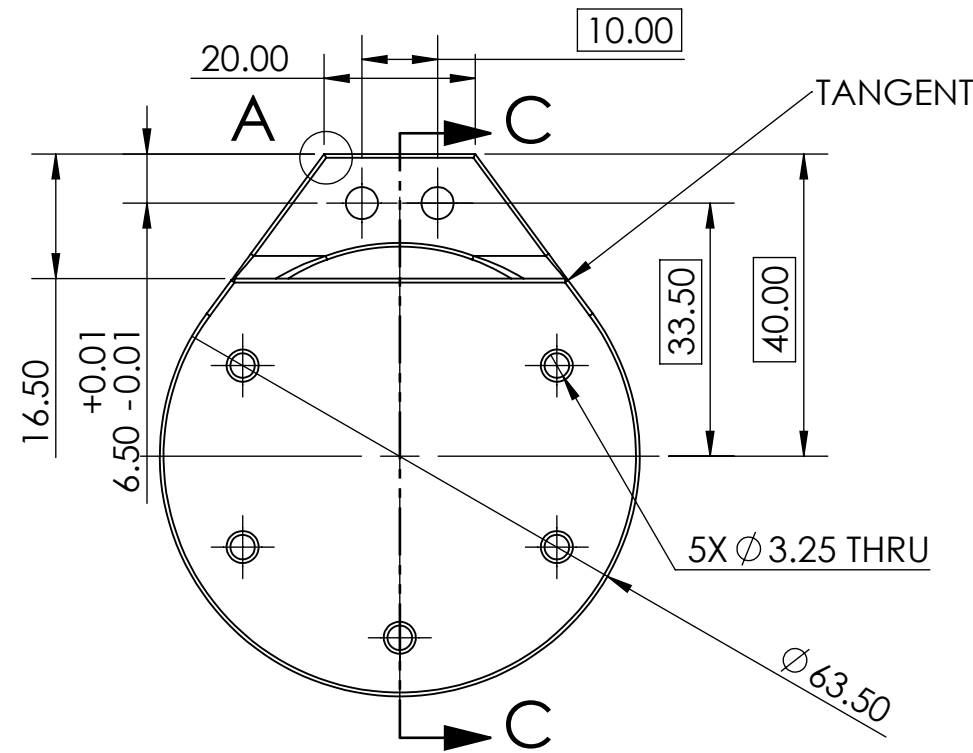
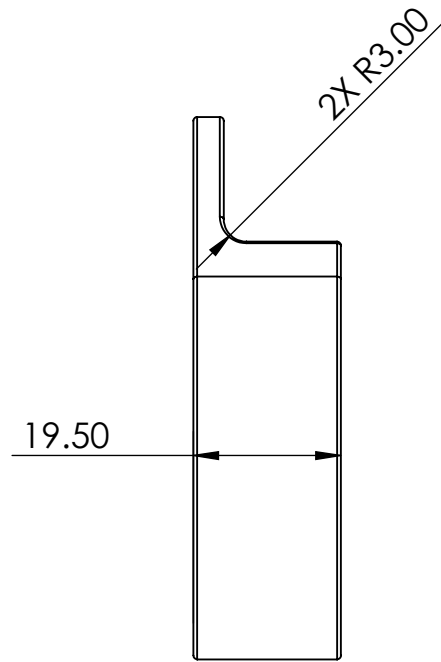
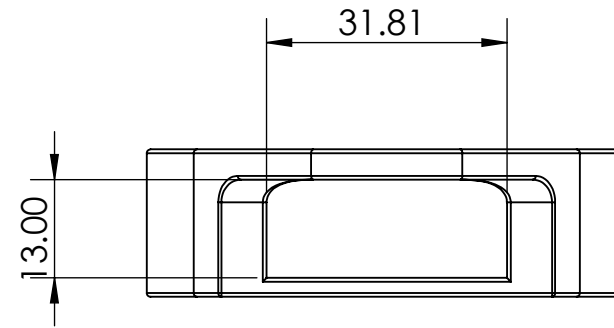

SECTION C-C  
SCALE 1:1

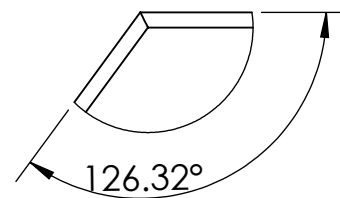

DETAIL A  
SCALE 4:1

**PROPRIETARY AND CONFIDENTIAL**  
 THE INFORMATION CONTAINED IN THIS DRAWING IS THE SOLE PROPERTY OF <INSERT COMPANY NAME HERE>. ANY REPRODUCTION IN PART OR AS A WHOLE WITHOUT THE WRITTEN PERMISSION OF <INSERT COMPANY NAME HERE> IS PROHIBITED.

		UNLESS OTHERWISE SPECIFIED:	NAME	DATE	TITLE: <b>DET006 REAR MOTOR MOUNT</b>
		DIMENSIONS ARE IN INCHES	DRAWN	C. LAMCA	
		TOLERANCES: FRACTIONAL ± ANGULAR: MACH ± BEND ± TWO PLACE DECIMAL ± THREE PLACE DECIMAL ±	CHECKED		
		INTERPRET GEOMETRIC TOLERANCING PER:	ENG APPR.		
		MATERIAL 3D Printed ONYX	MFG APPR.		SIZE DWG. NO. REV
NEXT ASSY	USED ON	FINISH	Q.A.		<b>B</b> <b>FINAL</b>
APPLICATION		DO NOT SCALE DRAWING	COMMENTS:		SCALE: 1:8 WEIGHT: SHEET 11 OF 16

3

2

1

4

3

2

1

UNITS IN mm UNLESS OTHERWISE SPECIFIED  
 ALL UNSPECIFIED RADII 0.5  
 THIS DRAWING ADHERES TO Y.14.5 DRAFTING STANDARDS  
 MATERIAL: 3D PRINTED ONYX BY MARKFORGED

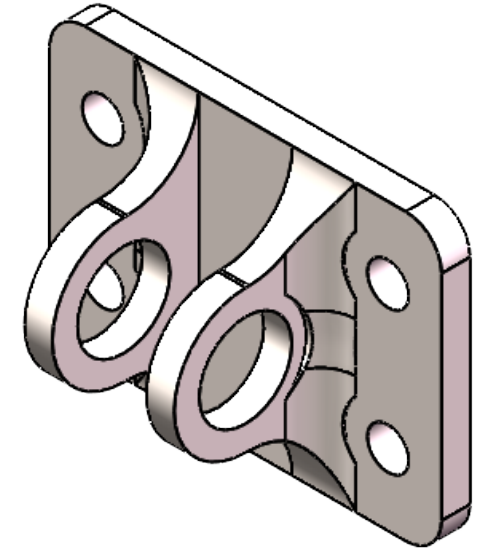

ISOMETRIC VIEW  
 SCALE: 4:3

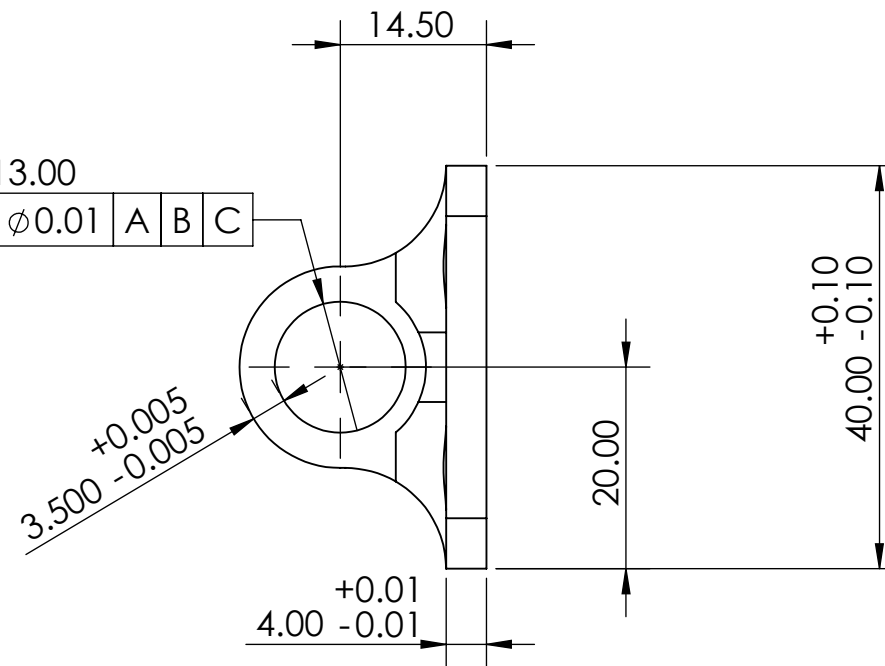
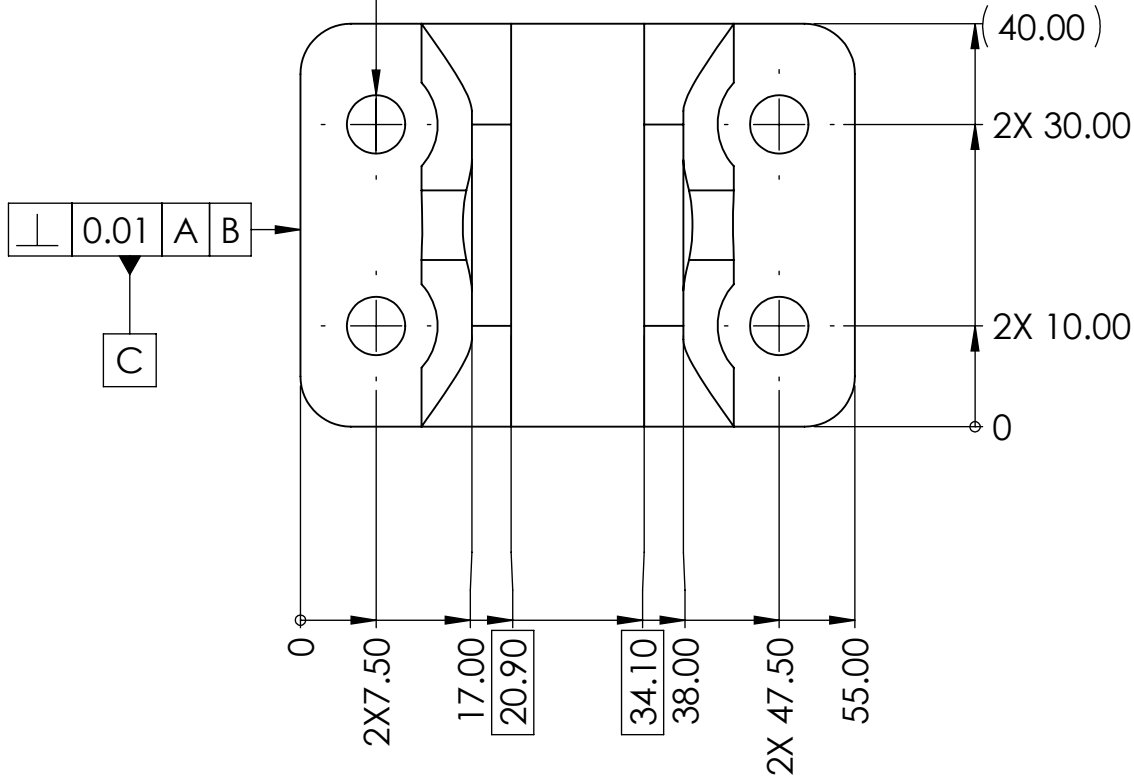
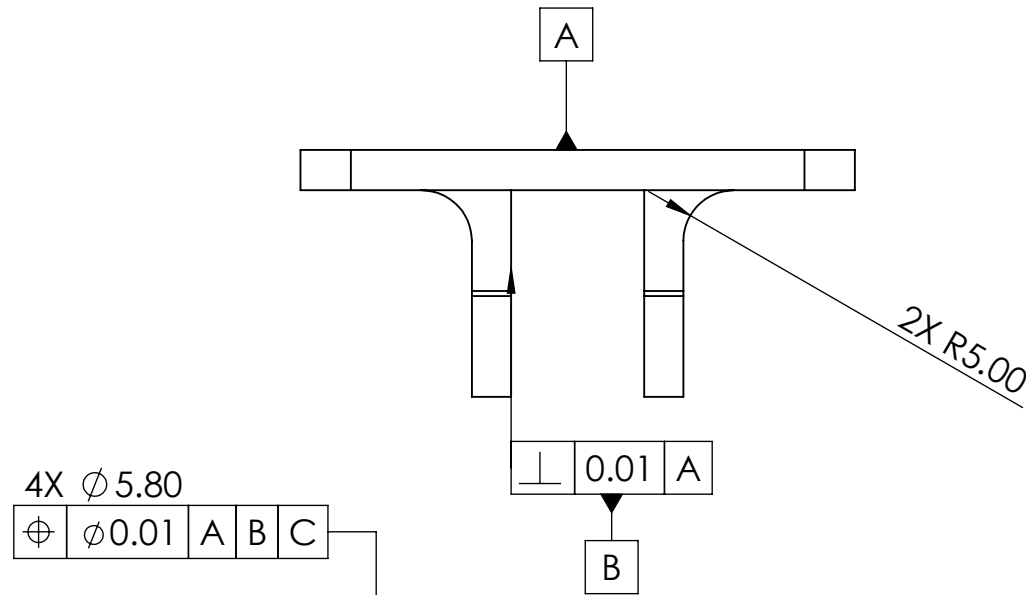

**PROPRIETARY AND CONFIDENTIAL**  
 THE INFORMATION CONTAINED IN THIS DRAWING IS THE SOLE PROPERTY OF <INSERT COMPANY NAME HERE>. ANY REPRODUCTION IN PART OR AS A WHOLE WITHOUT THE WRITTEN PERMISSION OF <INSERT COMPANY NAME HERE> IS PROHIBITED.

		UNLESS OTHERWISE SPECIFIED:	NAME	DATE	TITLE: <b>SUB01-DET001          HINGE BRACKET</b>
		DIMENSIONS ARE IN INCHES	DRAWN	C. LAMCA	
		TOLERANCES: FRACTIONAL ± ANGULAR: MACH ± BEND ± TWO PLACE DECIMAL ± THREE PLACE DECIMAL ±	CHECKED		
		INTERPRET GEOMETRIC TOLERANCING PER:	ENG APPR.		
		MATERIAL	MFG APPR.		SIZE
		AISI 316 SS	Q.A.		DWG. NO.
		FINISH	COMMENTS:		<b>B</b>
NEXT ASSY	USED ON	DO NOT SCALE DRAWING			<b>FINAL</b>
			SCALE: 1:8	WEIGHT:	REV
					SHEET 12 OF 16

3

2

1

4

3

2

1

UNITS IN mm UNLESS OTHERWISE SPECIFIED  
 ALL UNSPECIFIED RADII 0.5  
 THIS DRAWING ADHERES TO Y.14.5 DRAFTING STANDARDS  
 MATERIAL: 3D PRINTED ONYX BY MARKFORGED

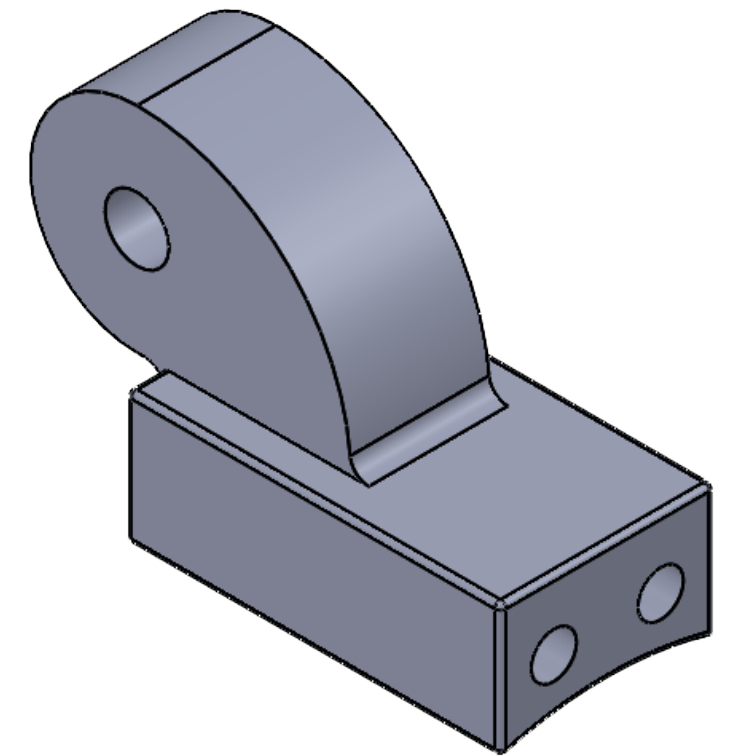
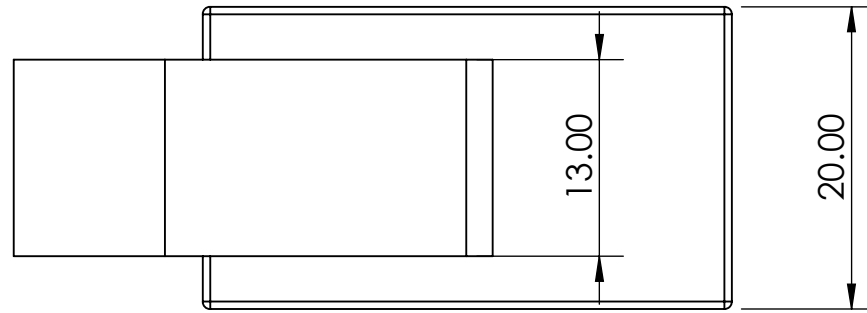

ISOMETRIC VIEW  
SCALE: 2:1

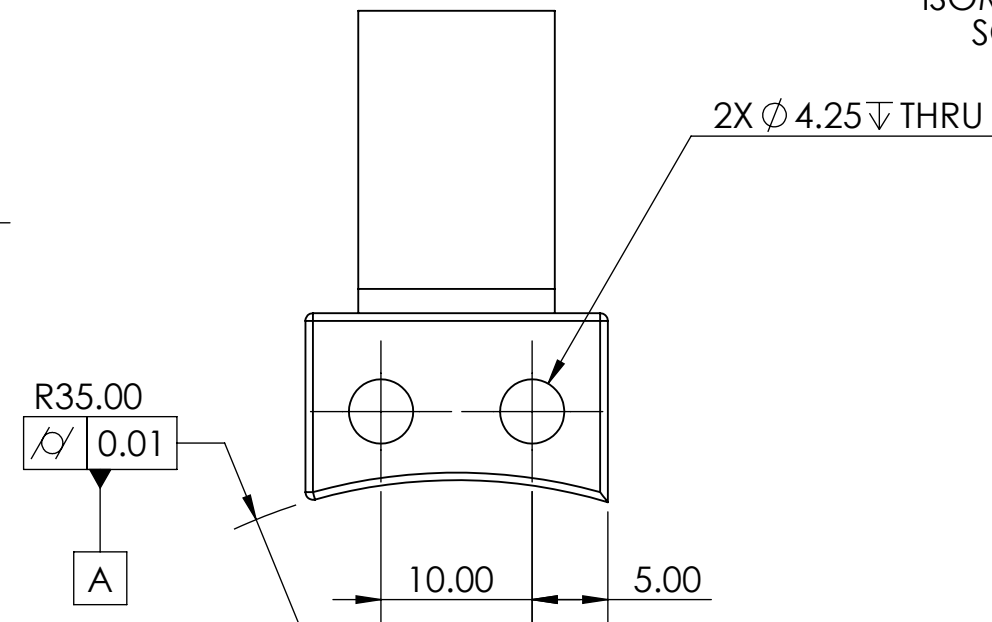
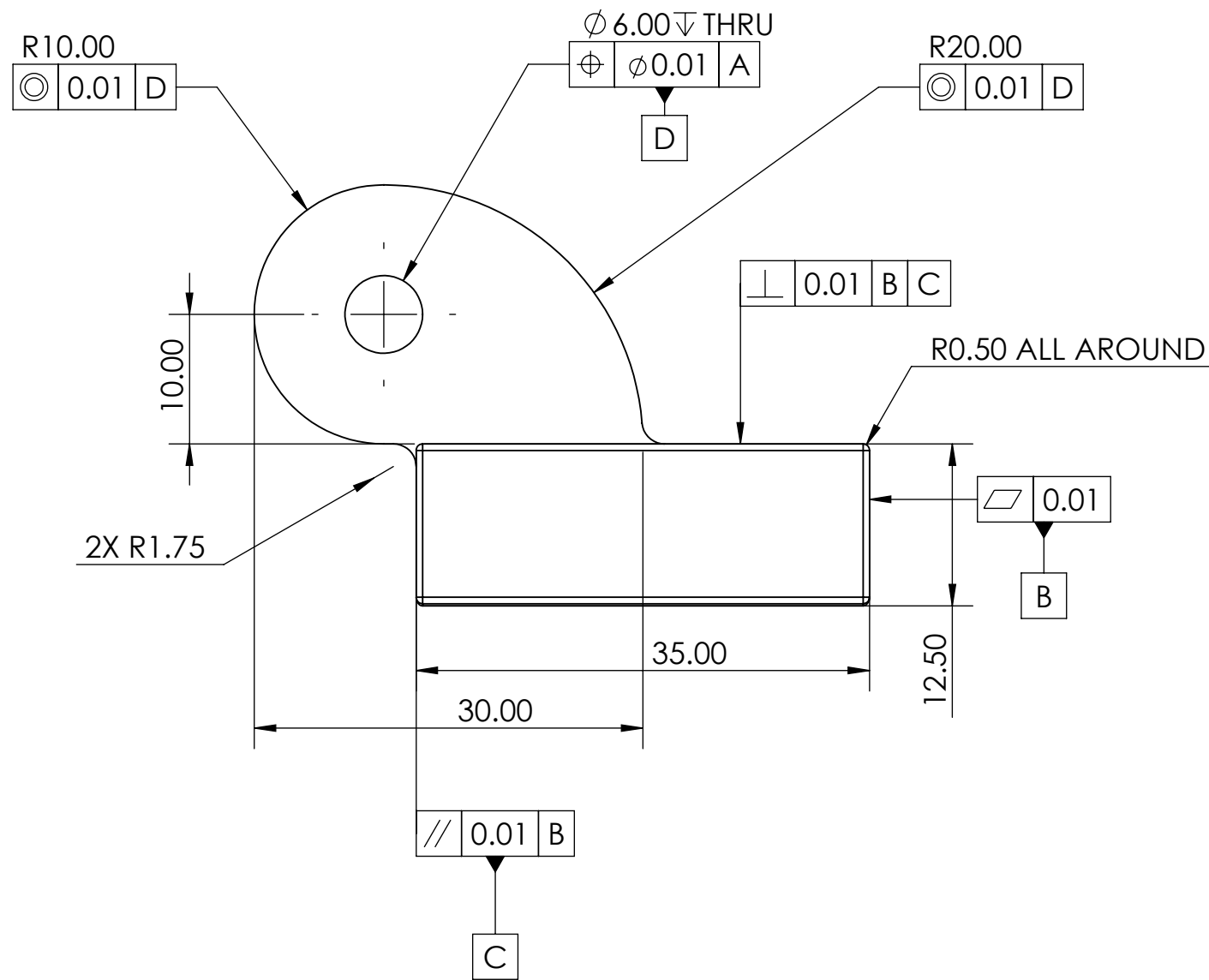

	NAME	DATE	TITLE:		
DRAWN	C. LAMCA		<b>SUB01-DET002</b> <b>HINGE CAM</b>		
CHECKED					
ENG APPR.					
MFG APPR.					
Q.A.					
COMMENTS:			SIZE	DWG. NO.	REV
			<b>B</b>	<b>FINAL</b>	
			SCALE: 1:8	WEIGHT:	SHEET 13 OF 16

3

2

1

4

3

2

1

UNITS IN mm UNLESS OTHERWISE SPECIFIED  
 ALL UNSPECIFIED RADII 0.5  
 THIS DRAWING ADHERES TO Y.14.5 DRAFTING STANDARDS  
 MATERIAL: 3D PRINTED ONYX BY MARKFORGED

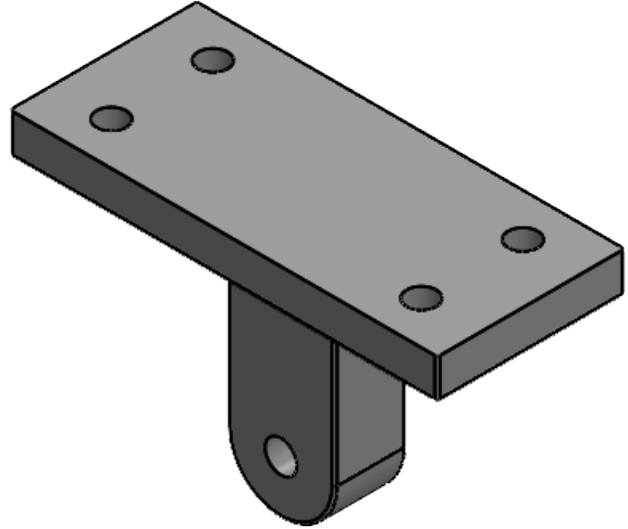

ISOMETRIC VIEW  
 SCALE: 1:1

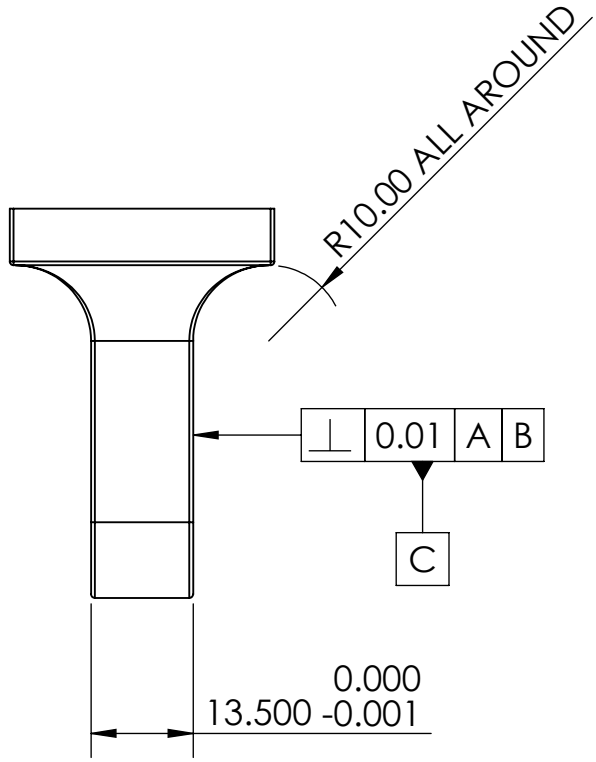
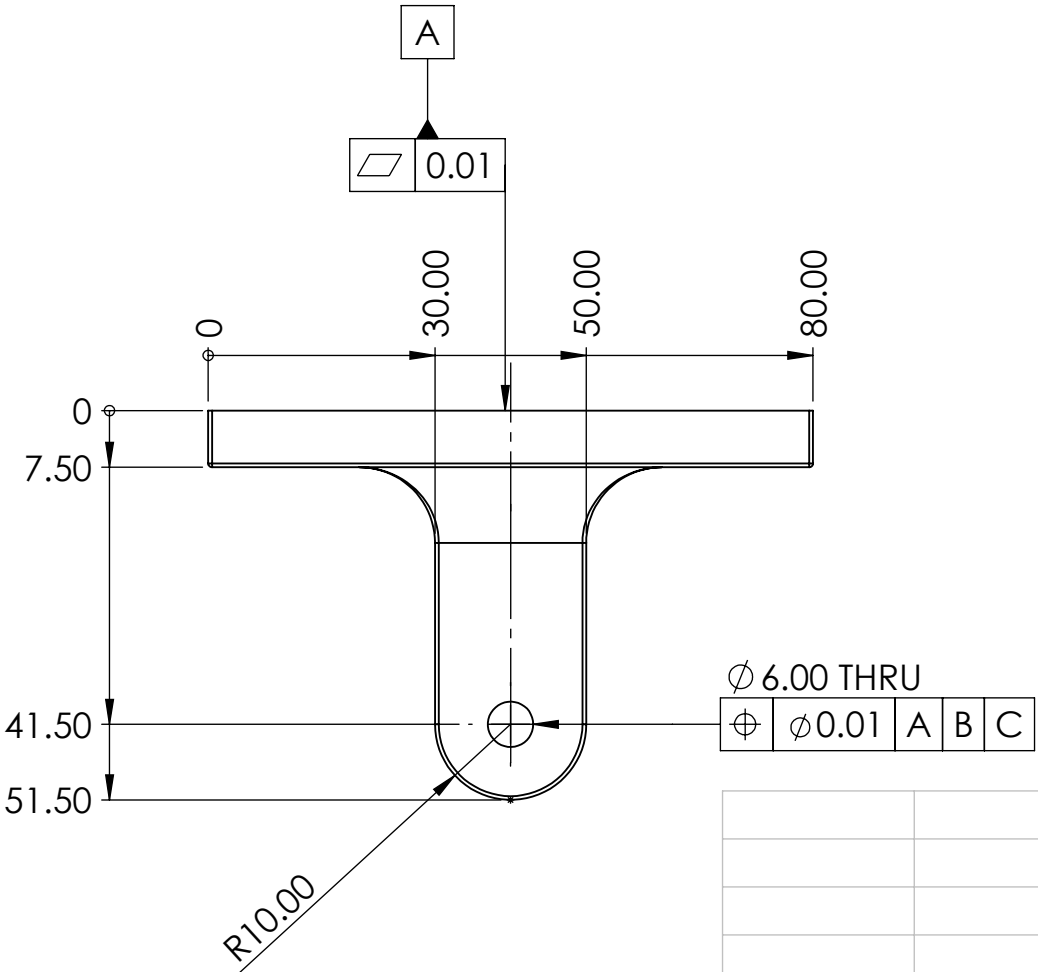
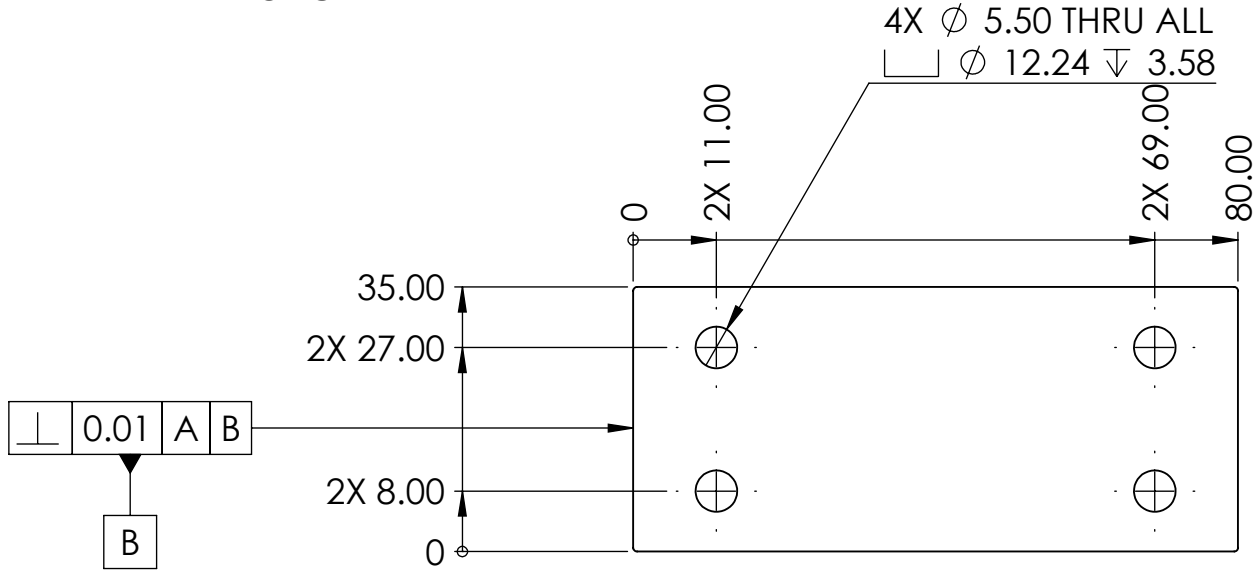

**PROPRIETARY AND CONFIDENTIAL**  
 THE INFORMATION CONTAINED IN THIS DRAWING IS THE SOLE PROPERTY OF <INSERT COMPANY NAME HERE>. ANY REPRODUCTION IN PART OR AS A WHOLE WITHOUT THE WRITTEN PERMISSION OF <INSERT COMPANY NAME HERE> IS PROHIBITED.

UNLESS OTHERWISE SPECIFIED:		NAME	DATE
DIMENSIONS ARE IN INCHES		DRAWN	C. LAMCA
TOLERANCES:		CHECKED	
FRACTIONAL $\pm$		ENG APPR.	
ANGULAR: MACH $\pm$ BEND $\pm$		MFG APPR.	
TWO PLACE DECIMAL $\pm$		Q.A.	
THREE PLACE DECIMAL $\pm$		COMMENTS:	
INTERPRET GEOMETRIC TOLERANCING PER:			
MATERIAL			
3D Printed ONYX			
FINISH			
NEXT ASSY	USED ON		
APPLICATION			
DO NOT SCALE DRAWING			

TITLE:  
**SUB03-DET001  
 CUFF ATTACHMENT**

SIZE DWG. NO. REV  
**B FINAL**

SCALE: 1:8 WEIGHT: SHEET 14 OF 16

3

2

1

UNITS IN mm UNLESS OTHERWISE SPECIFIED  
 ALL UNSPECIFIED RADII 0.5  
 THIS DRAWING ADHERES TO Y.14.5 DRAFTING STANDARDS  
 MATERIAL: 3D PRINTED ONYX BY MARKFORGED

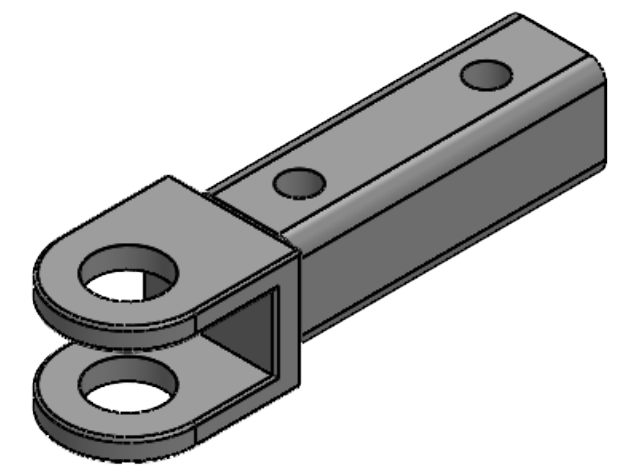

ISOMETRIC VIEW  
 SCALE: 1:1

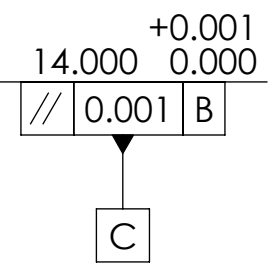
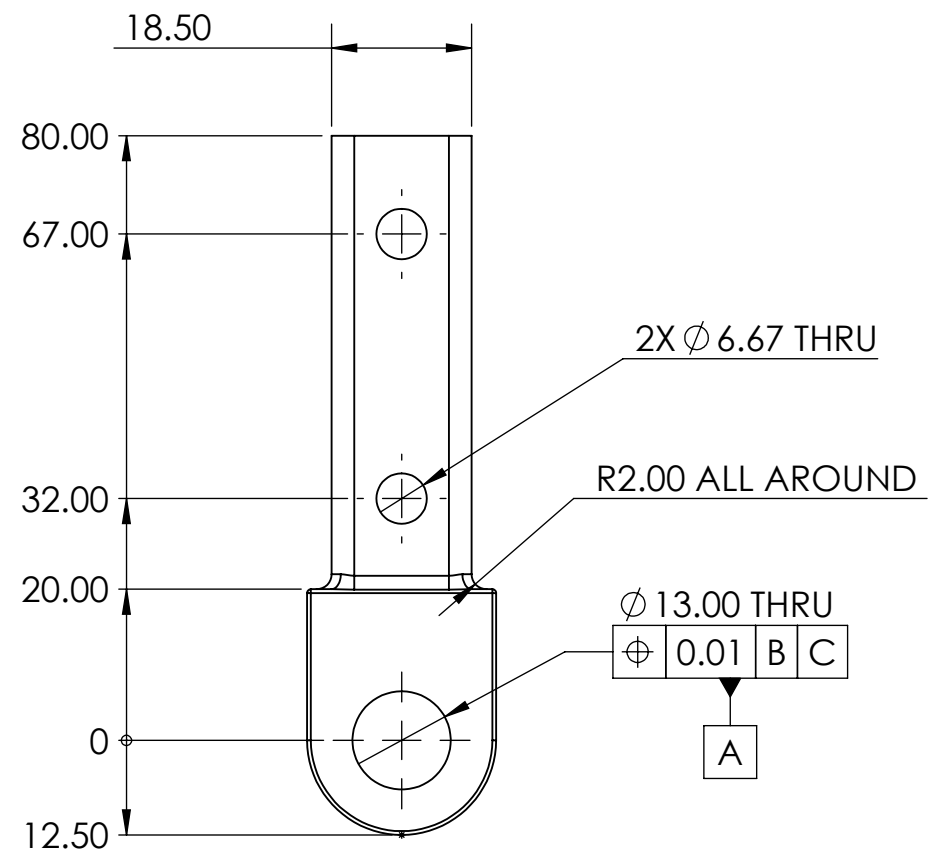
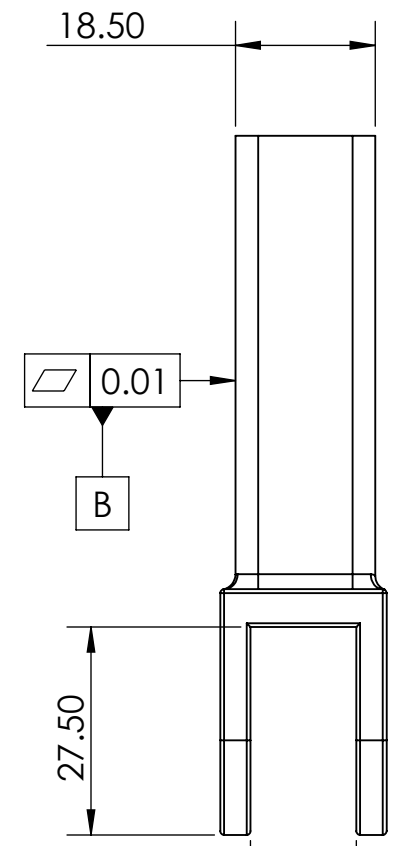
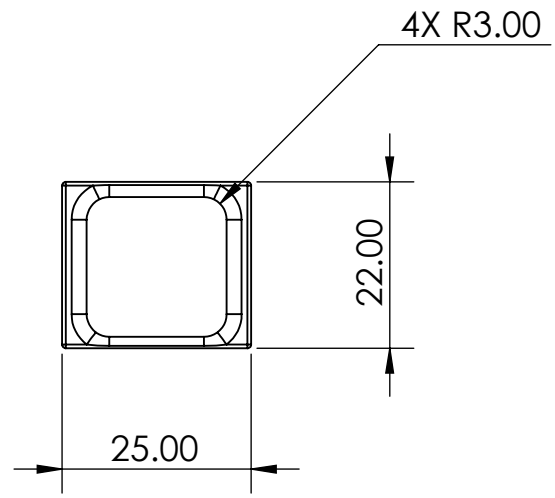

**PROPRIETARY AND CONFIDENTIAL**  
 THE INFORMATION CONTAINED IN THIS DRAWING IS THE SOLE PROPERTY OF <INSERT COMPANY NAME HERE>. ANY REPRODUCTION IN PART OR AS A WHOLE WITHOUT THE WRITTEN PERMISSION OF <INSERT COMPANY NAME HERE> IS PROHIBITED.

		UNLESS OTHERWISE SPECIFIED:	NAME	DATE	TITLE: <b>SUB03-DET002 LINK ATTACHMENT</b>
		DIMENSIONS ARE IN INCHES	DRAWN	C. LAMCA	
		TOLERANCES: FRACTIONAL ± ANGULAR: MACH ± BEND ± TWO PLACE DECIMAL ± THREE PLACE DECIMAL ±	CHECKED		
		INTERPRET GEOMETRIC TOLERANCING PER:	ENG APPR.		
		MATERIAL 3D Printed ONYX	MFG APPR.		SIZE DWG. NO. REV
NEXT ASSY	USED ON	FINISH	Q.A.		<b>B</b> <b>FINAL</b>
APPLICATION		DO NOT SCALE DRAWING	COMMENTS:		SCALE: 1:8 WEIGHT: SHEET 15 OF 16

UNITS IN mm UNLESS OTHERWISE SPECIFIED  
 ALL UNSPECIFIED RADII 0.5  
 THIS DRAWING ADHERES TO Y.14.5 DRAFTING STANDARDS  
 MATERIAL: 3D PRINTED ONYX BY MARKFORGED

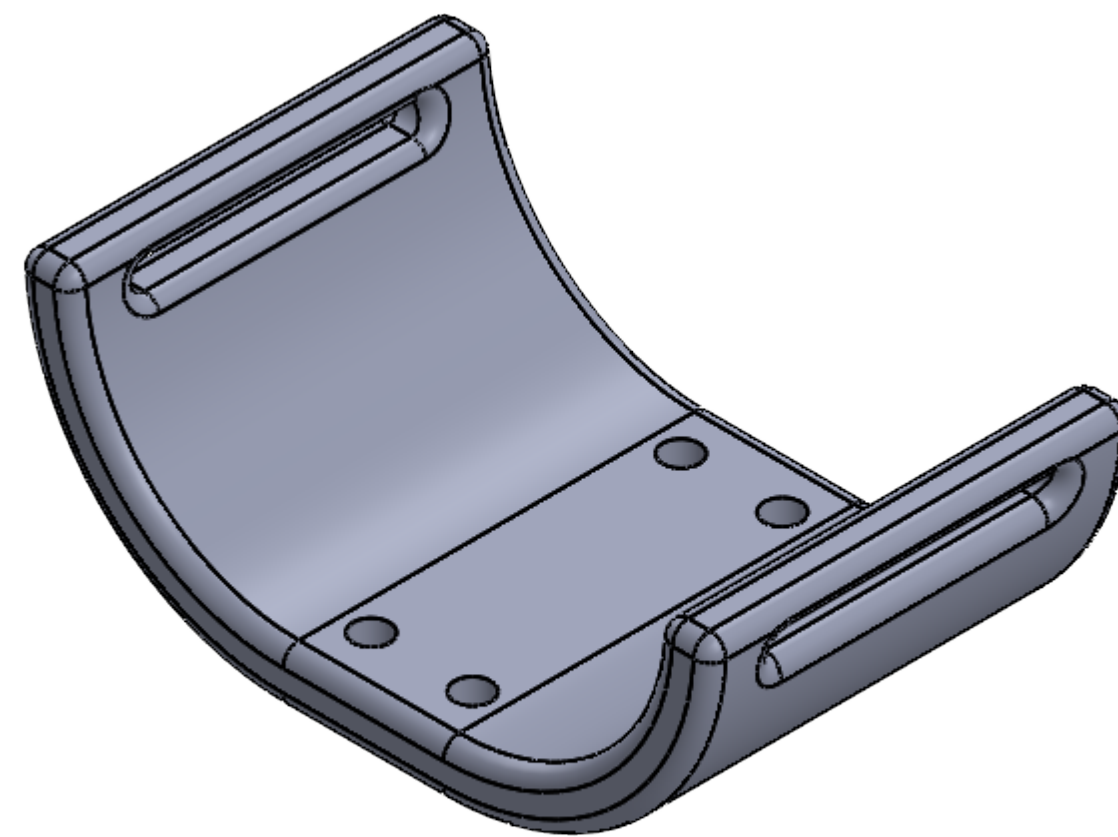
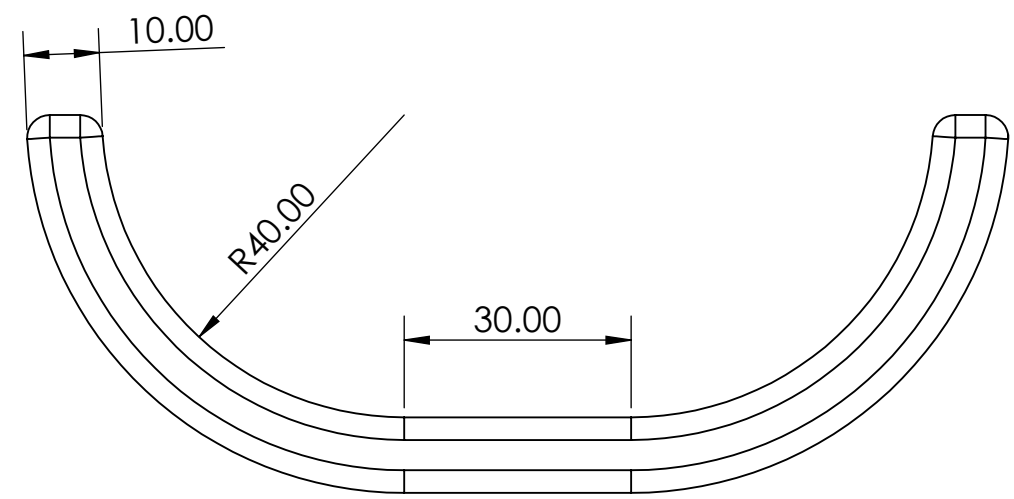
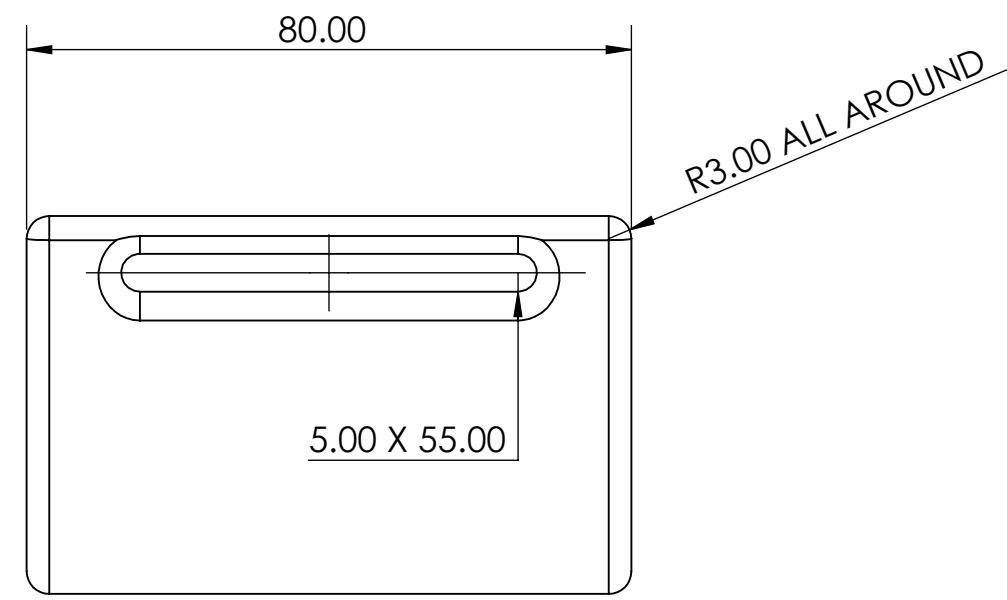

ISOMETRIC VIEW  
 SCALE: 1:1

## MEDIUM CUFF SIZE

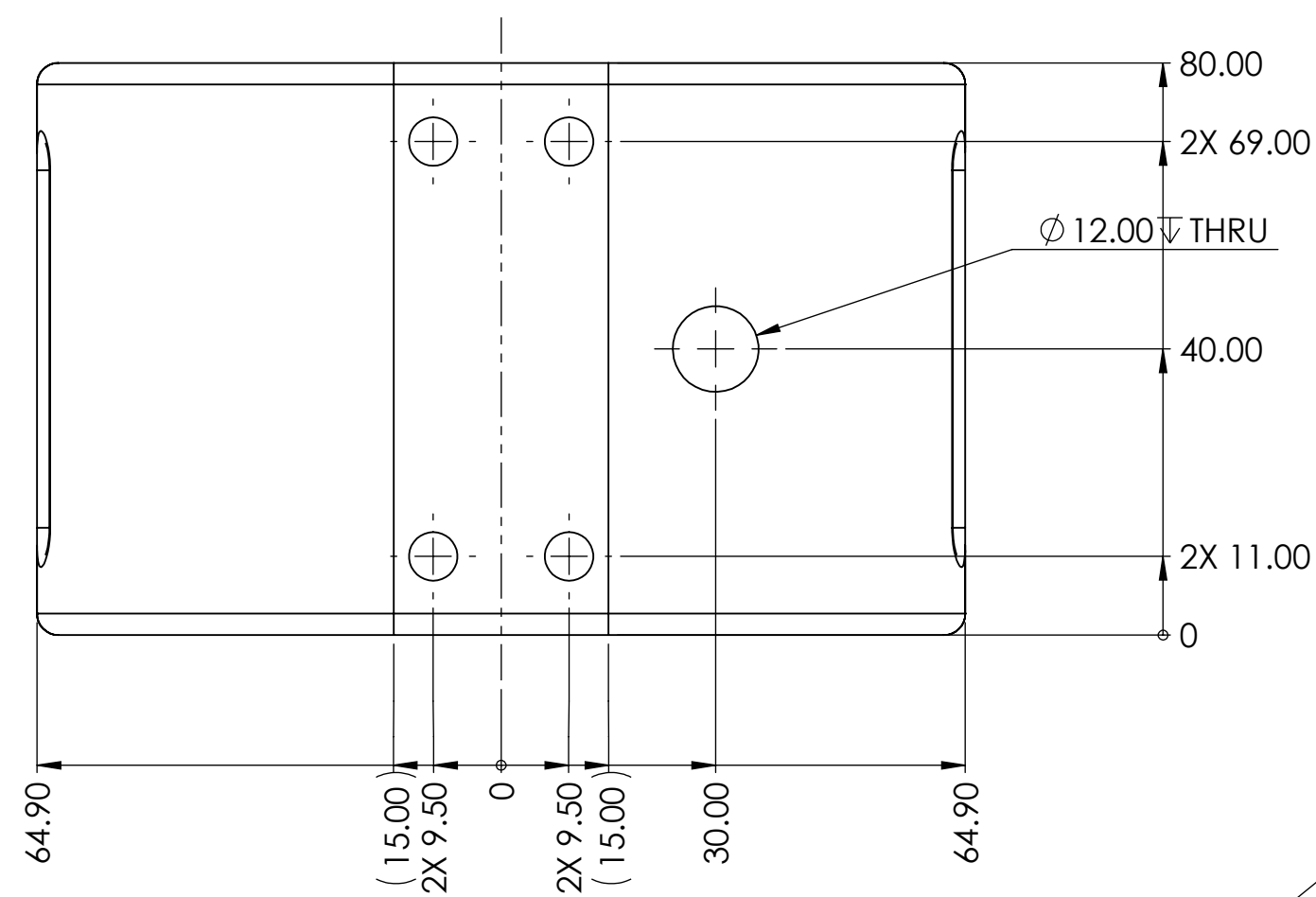

UNITS IN mm UNLESS OTHERWISE SPECIFIED  
 ALL UNSPECIFIED RADII 0.5  
 THIS DRAWING ADHERES TO Y.14.5 DRAFTING STANDARDS  
 MATERIAL: 3D PRINTED ONYX BY MARKFORGED

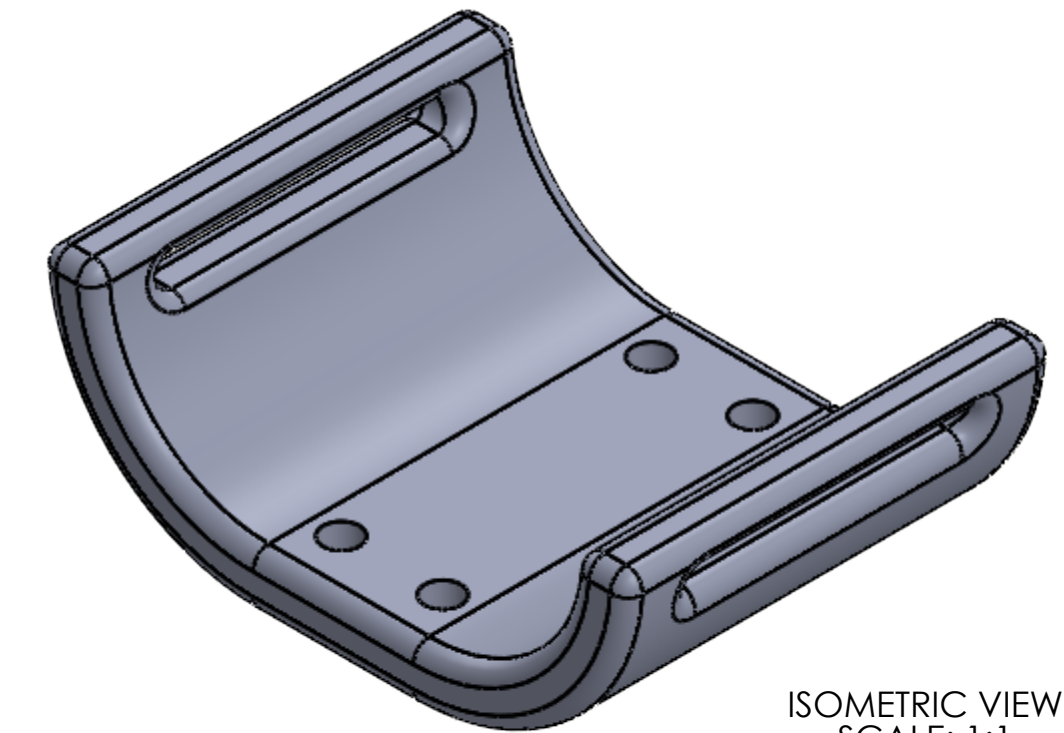
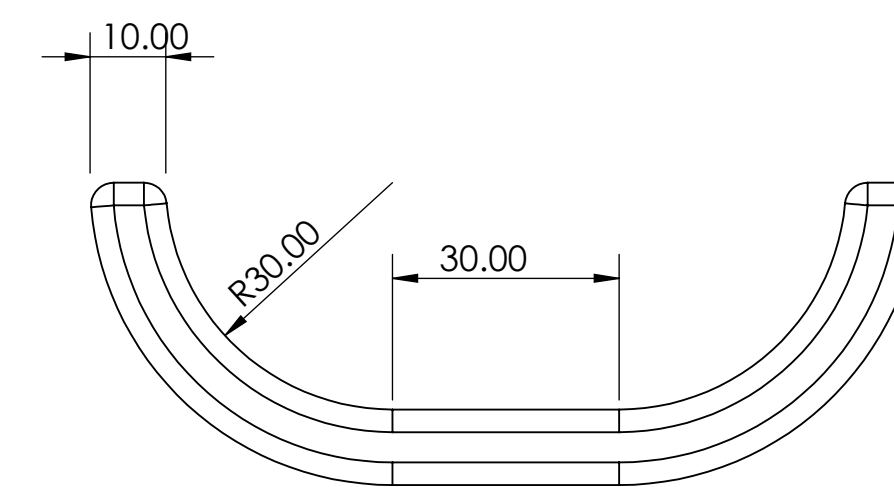
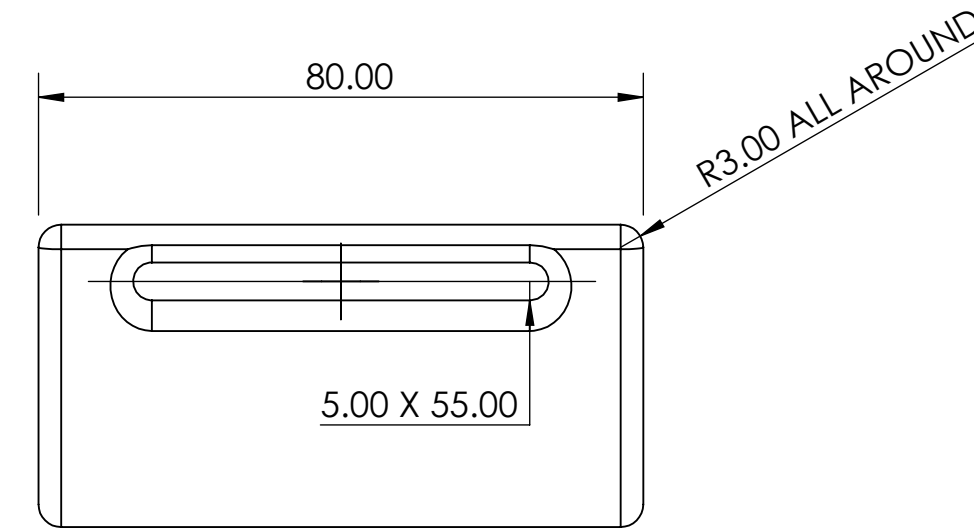

ISOMETRIC VIEW  
 SCALE: 1:1

## SMALL CUFF SIZE

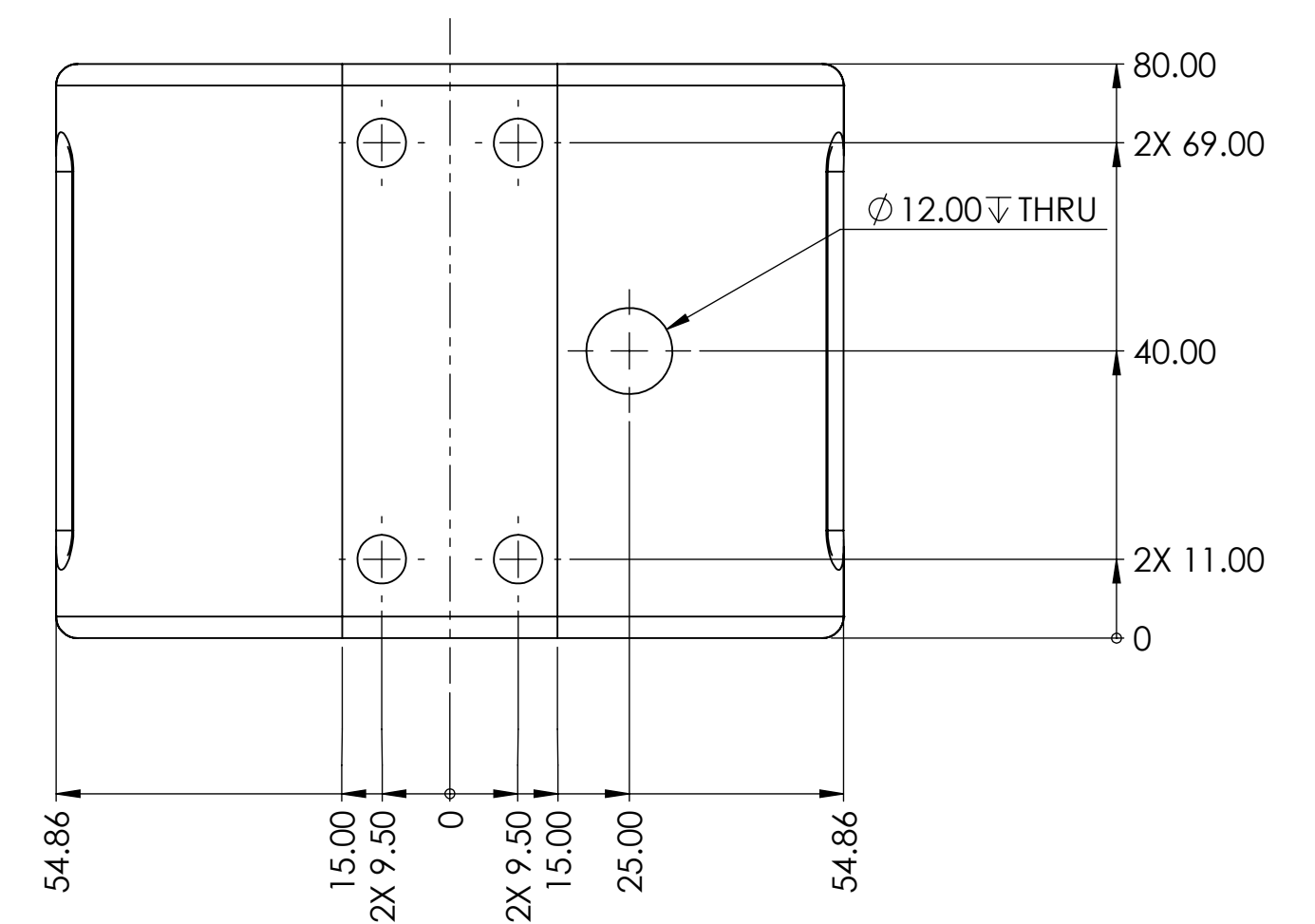

UNITS IN mm UNLESS OTHERWISE SPECIFIED  
 ALL UNSPECIFIED RADII 0.5  
 THIS DRAWING ADHERES TO Y.14.5 DRAFTING STANDARDS  
 MATERIAL: 3D PRINTED ONYX BY MARKFORGED

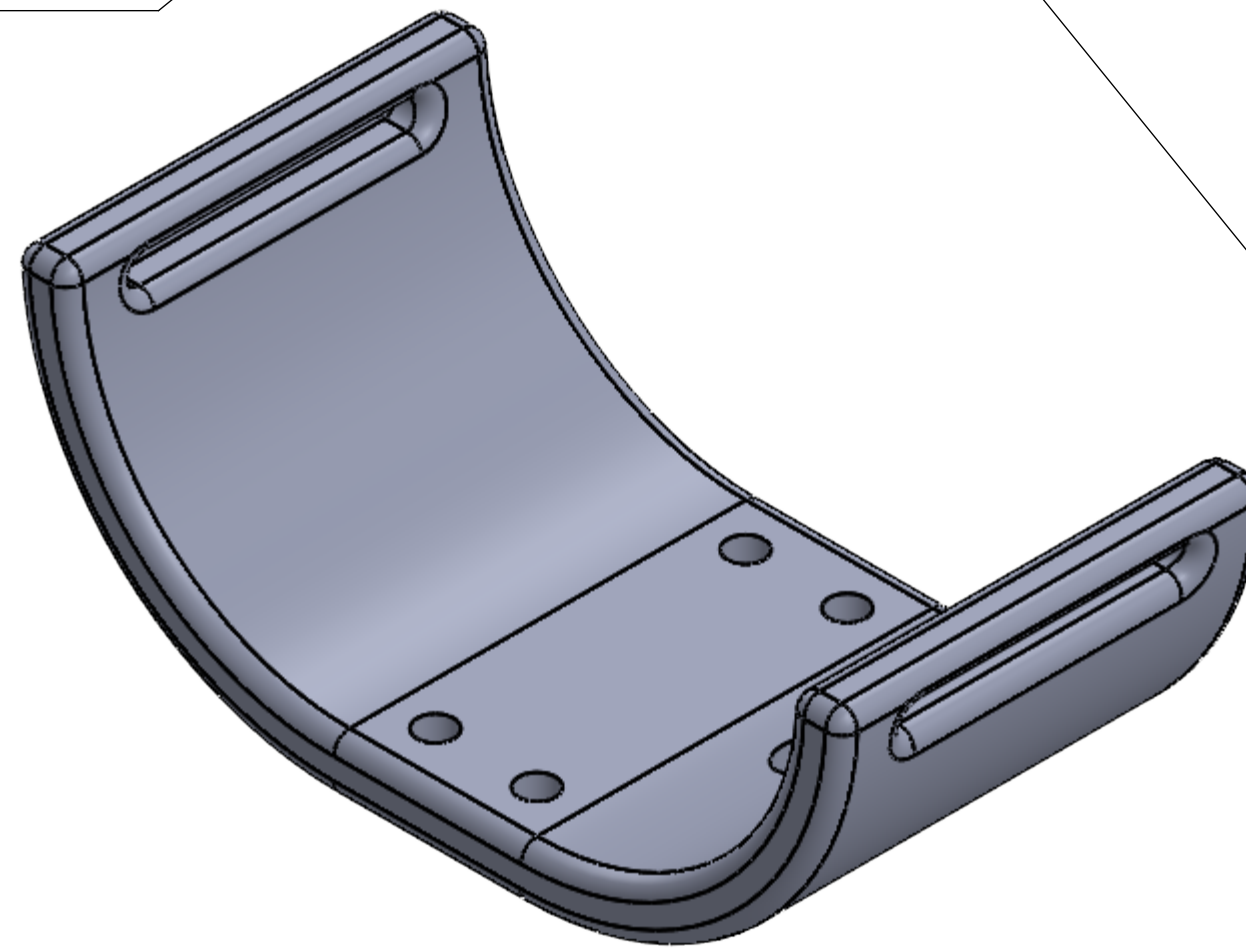
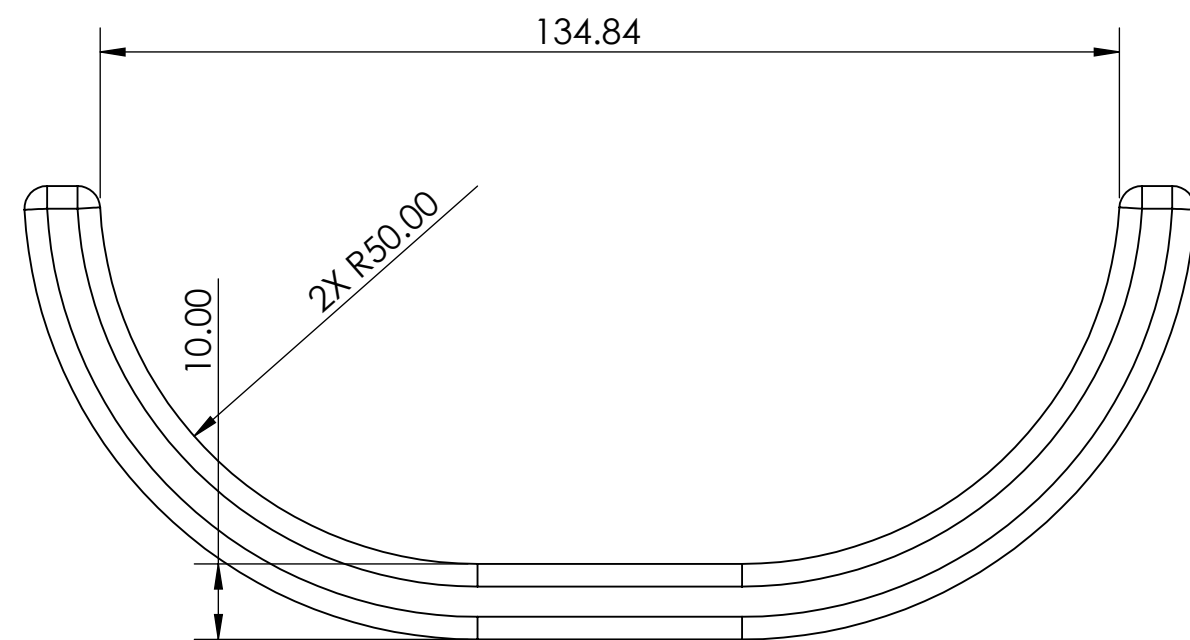
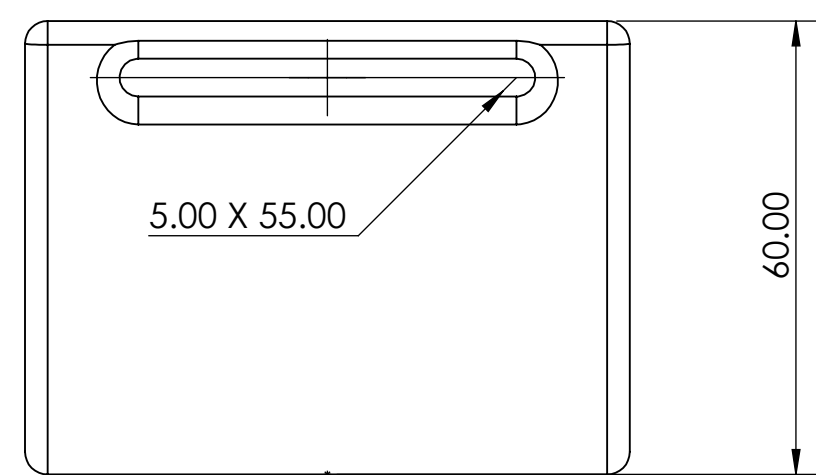

ISOMETRIC VIEW  
 SCALE: 1:1

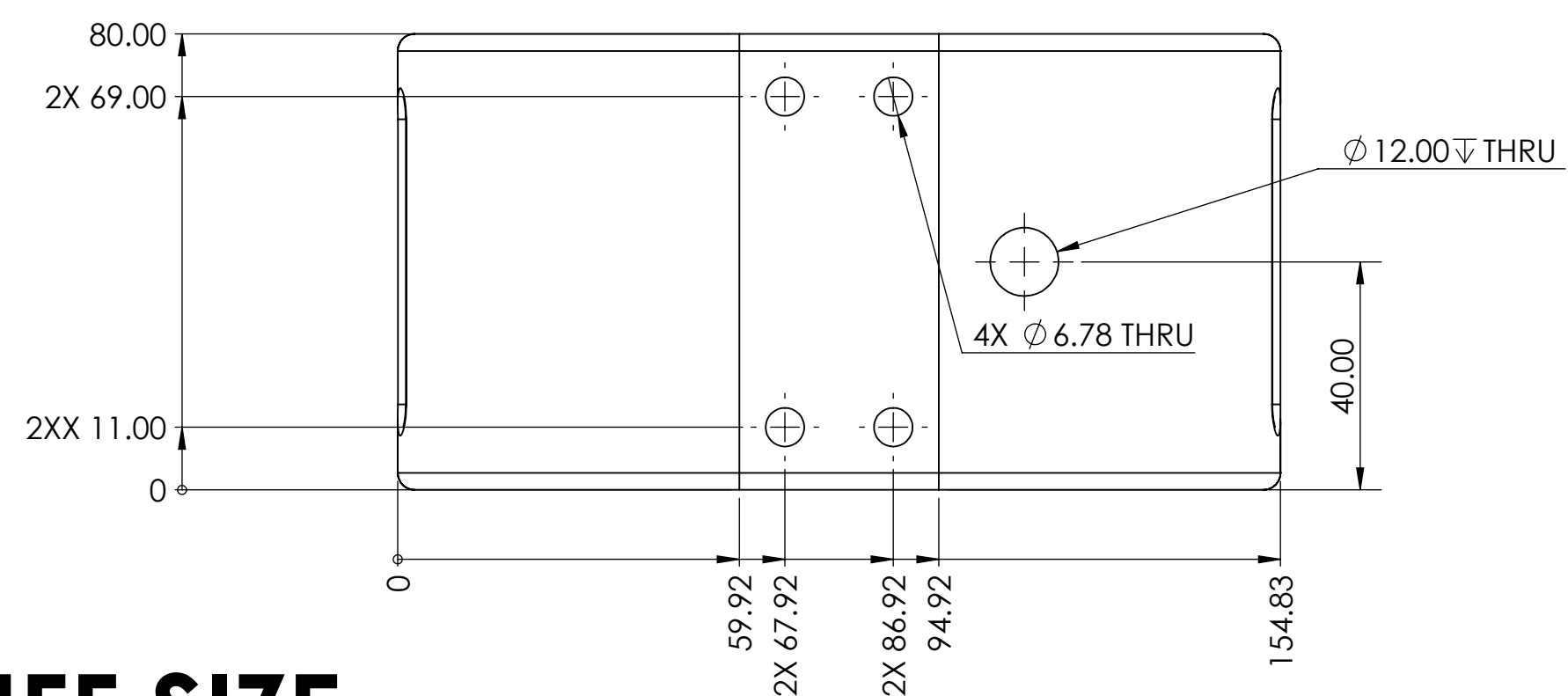

## LARGE CUFF SIZE

PROPRIETARY AND CONFIDENTIAL  
 THE INFORMATION CONTAINED IN THIS  
 DRAWING IS THE SOLE PROPERTY OF  
 «INSERT COMPANY NAME HERE». ANY  
 REPRODUCTION IN PART OR AS A WHOLE  
 WITHOUT THE WRITTEN PERMISSION OF  
 «INSERT COMPANY NAME HERE» IS  
 PROHIBITED.

UNLESS OTHERWISE SPECIFIED:		NAME	DATE
DIMENSIONS ARE IN INCHES	DRAWN		
TOLERANCES:	CHECKED		
FRACTIONAL ±	ENG APPR.		
ANGULAR ± MATCH ± BEND ±	MFG APPR.		
TWO PLACE DECIMAL ±	Q.A.		
THREE PLACE DECIMAL ±	COMMENTS:		
INTERPRET GEOMETRIC TOLERANCING PER:			
MATERIAL:			
FINISH:			
NEXT ASSY	USED ON		
APPLICATION	DO NOT SCALE DRAWING		

TITLE:		
SUB03-DET003 CUFF		
SIZE	DWG. NO.	REV
D	FINAL	
SCALE: 1:8	WEIGHT:	SHEET 16 OF 16